

1999 Automotive Alternative Refrigerant Systems Forum

Title :

Experimental Evaluation of The Prototype CO₂ System and The HFC-134a System In Wind Tunnel

Authors :

Kiyokazu Yamamoto, Shunji Komatsu
Corporate R&D
Sanden Corporation

Presented on June 30, 1999

Phoenix, June 28-July 1, 1999



SANDEN

Experimental evaluation of CO₂ system and the HFC-134a system in a Wind Tunnel

1. An Approach Towards Alternative Refrigerant for HFC134a Automotive A/C.

- (1) Industry concerns were raised, at the 1998 Kyoto Conference (COP3) which listed the HFC family as one of the six substances causing most damage to global warming. Worldwide consensus will play a significant role in the introduction and timing of CO₂ as the third refrigerant.
- (2) Active R&D efforts are underway to minimize leak amount (direct effect) and energy consumption (indirect effect) of compressors for the current HFC134a system.
- (3) Consistent with commitment to the environment, and potential future customer requirements, tests of the compressors for CO₂ transcritical cycle automotive A/C system is continuing.

Phoenix, June 28-July 1, 1999



SANDEN

Experimental evaluation of CO₂ system and the HFC-134a system in a Wind Tunnel

2. CO₂ A/C Systems Requirements

Under the condition determined for the specific range of geographical area or the seasonal climate change, compressor test specification must be drafted from the system operation data.

- (1) TEWI must be smaller than that of HFC-134a system.
- (2) Cooling performance and COP must be greater than that of HFC-134a system.
- (3) Total system weight must be less than that of HFC-134a. In order not to adversely impact the size and weight of the vehicle, the size of each component must be comparable or smaller than current system.
- (4) Reliability and durability must be equal or better than that of the current A/C system.
- (5) To assure and improve serviceability, global standards must be formulated and agreed upon.

Phoenix, June 28-July 1, 1999



Experimental evaluation of CO₂ system and the HFC-134a system in a Wind Tunnel

3. Direction Of System Engineers for CO₂ System Vehicle Applications

- (1) As a compressor manufacture, Sanden believe that Variable displacement compressors should be used for a better TEWI₍₁₎.
- (2) In order for the system engineers to improve economic viability, it is advantageous to maintain system configuration and components as simple as possible, thus making it possible to utilize the existing manufacturing facilities as much as possible.
- (3) System controls will be simplified as much as possible. For the system engineers, the possibility of utilizing conventional expansion device concept is worth further investigation.

(1) Evaluation of Mobile A/C System for Environment Protection, SANDEN's presentation in the 98 Phoenix Project-Industry Forum on Mobile A/C Alternate Cooling, July 1998 SAE Interior Climate Control Committee

Phoenix, June 28-July 1, 1999



Experimental evaluation of CO₂ system and the HFC-134a system in a Wind Tunnel

4-1. Description Of Cycle Configuration

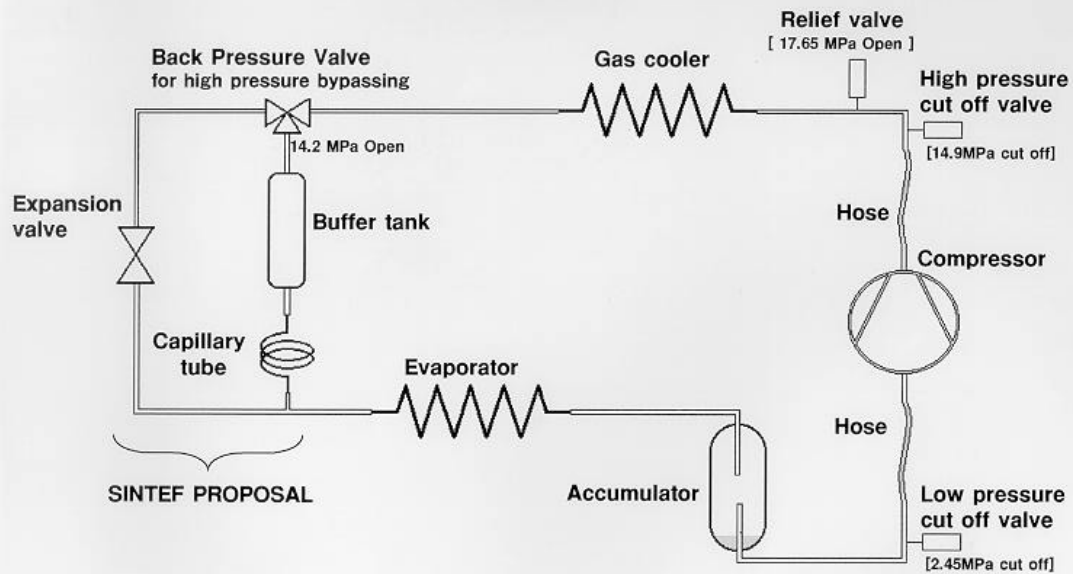

Phoenix, June 28-July 1, 1999

SANDEN

Experimental evaluation of CO₂ system and the HFC-134a system in a Wind Tunnel

4-2. Description Of Cycle Configuration

① with constant outlet pressure type expansion valve

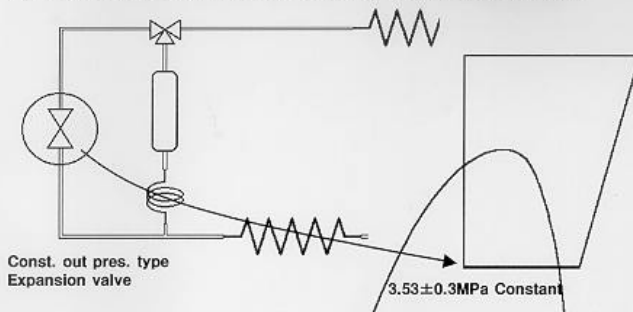

② with superheat control type expansion valve

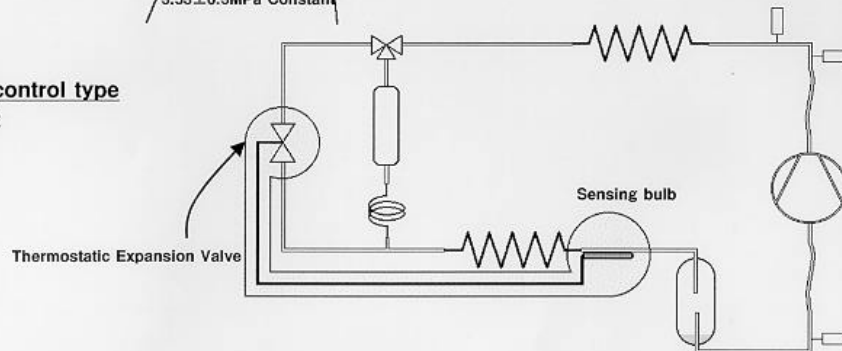

Phoenix, June 28-July 1, 1999

SANDEN

Experimental evaluation of CO₂ system and the HFC-134a system in a Wind Tunnel

4-3. Components Of Reference HFC-134a System And Prototype CO₂ System

	HFC - 134a system	Prototype CO ₂ system
Compressor	Displacement Max :161cc/rev Variable Comp. Drive ratio:1.08	Displacement 29.8cc/rev Fixed displacement Drive ratio:1.08
Evaporator	Fin and Tube W 261×H 228×L 80	Serpentine type W 259×H 226×L 80
Condenser/ Gas cooler	Multi-flow type W 600×H 341×L 20	Const. V. Proto.#1 Serpentine type w609×H341×L32
		T.X.V Proto.#2 Multi-flow type w606×H342×L16
Control	Thermostatic Expansion valve	Proto.#1 Constant out pres. type Proto.#2 Thermostatic expansion valve Back pressure valve
Protective Device	High pres. cut off switch 3.14MPa off Low pres. cut off switch 1.57MPa off Relief valve 3.9MPa off	High pres. cut off switch 14.9MPa off Low pres. cut off switch 2.45MPa off Relief valve 17.65MPa off
Receiver/ Accumulator	Receiver ϕ 75 mm × 168 mm	Accumulator ϕ 51 mm × 200 mm



4-4. Wind Tunnel Test Conditions (after RACE)

Phase	Soaking		Test		
	Preconditioning	Passive Heating	32km/h	64km/h	Idle
Time [min]	480	90	30*	30	80
Temperature [°C]	40	40	40	40	40
Rel. Humidity [%]	25	25	25	25	25
Sol. Radiation [w/m ²]	0	950	950	950	950
Engine Speed [rpm]	0	0	1600	1860	865
Velocity of Wind [km/h]	12	0	32	64	7
Inside Moistening [g/h]	0	0	0	0	0
A/C Setting			Fan : Max. Temperature Setting : Min. Air Recirculation : 100%		



5-1. Pull-Down Performance, CO₂ With Constant Outlet Pressure Type Expansion Valve

9

(Condition) Ambient temperature & humidity : 40°C, 25% Sol. Radiation : 950W/m²

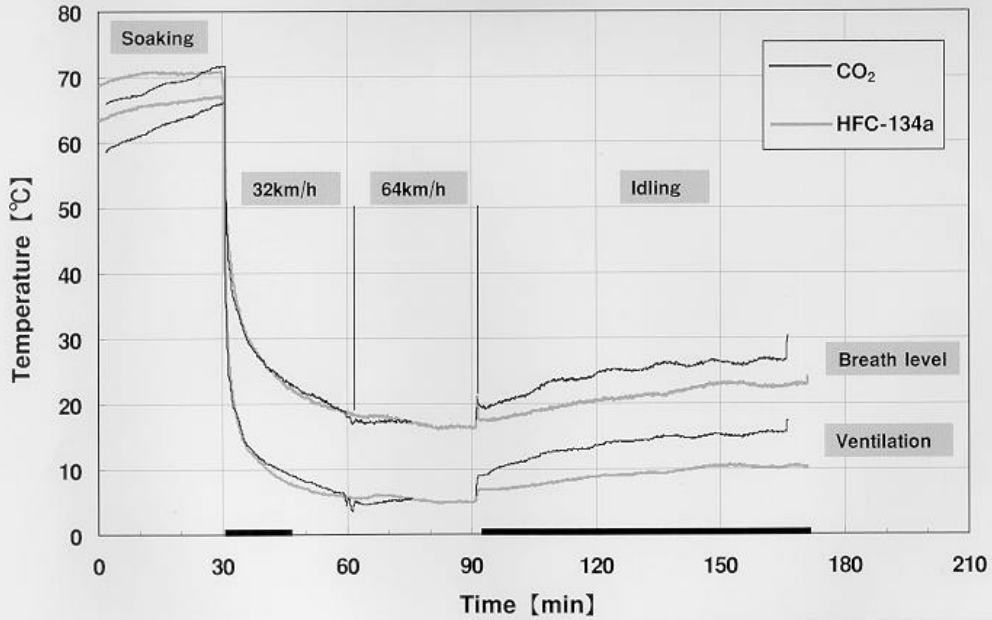

SANDEN

Phoenix, June 28-July 1, 1999

Experimental evaluation of CO₂ system and the HFC-134a system in a Wind Tunnel

5-2. Pull-Down Performance, CO₂ With Superheat Control Type Expansion Valve

10

(Condition) Ambient temperature & humidity : 40°C, 25% Sol. Radiation : 950W/m²

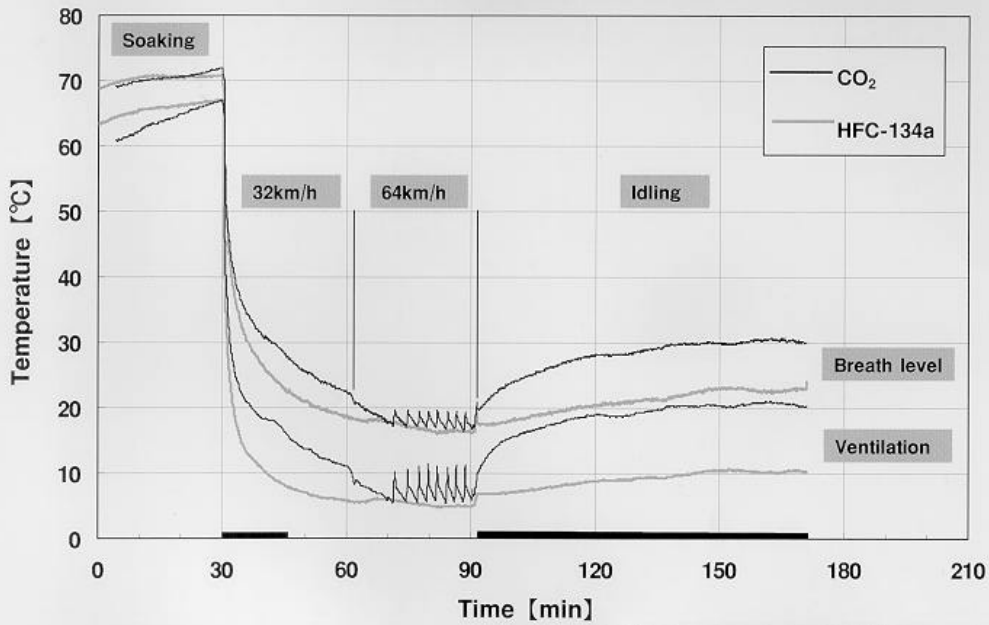

SANDEN

Phoenix, June 28-July 1, 1999

Experimental evaluation of CO₂ system and the HFC-134a system in a Wind Tunnel

One Of The Vehicles With CO₂ System Installed

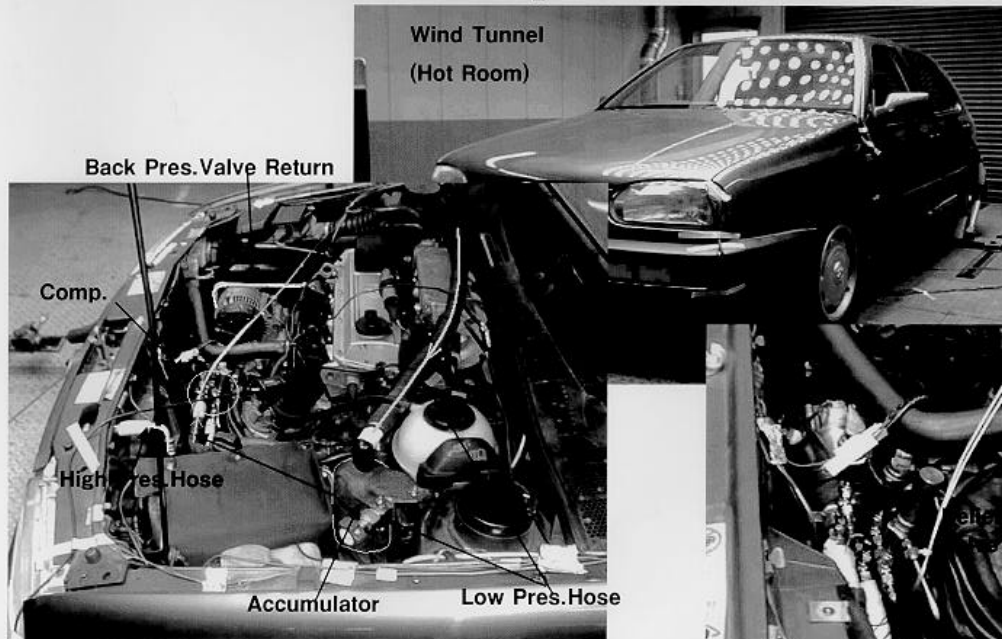

Phoenix, June 28-July 1, 1999

SANDEN

Experimental evaluation of CO₂ system and the HFC-134a system in a Wind Tunnel

Prototype Compressor

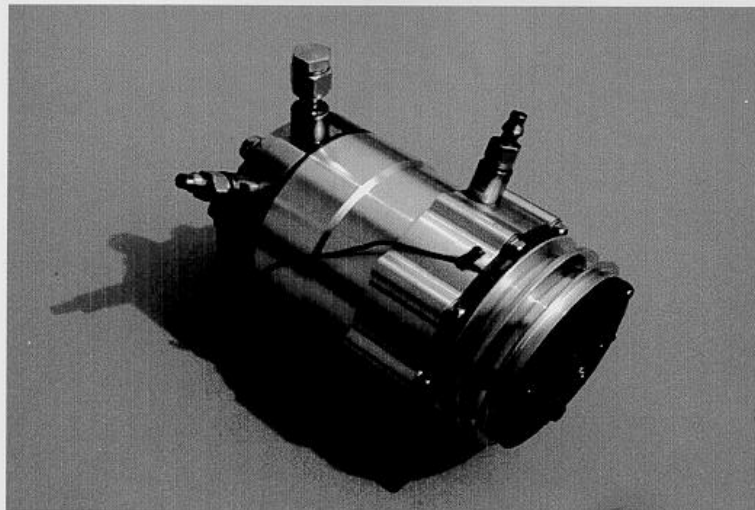

**Swash-Plate
Displacement : 29.8cc**

Phoenix, June 28-July 1, 1999

SANDEN

Experimental evaluation of CO₂ system and the HFC-134a system in a Wind Tunnel

Prototype Evaporator

W 256mm × H 226mm × L 80mm

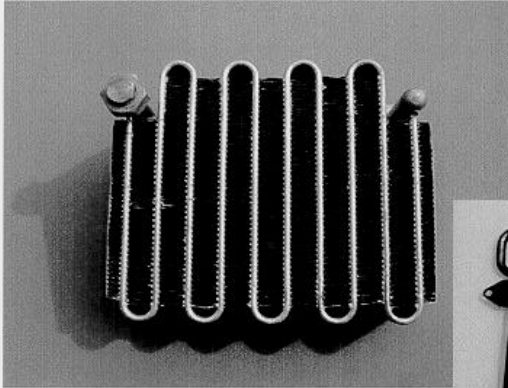

Serpentine type

Prototype Gas cooler

W 606mm × H 342mm × L 16mm

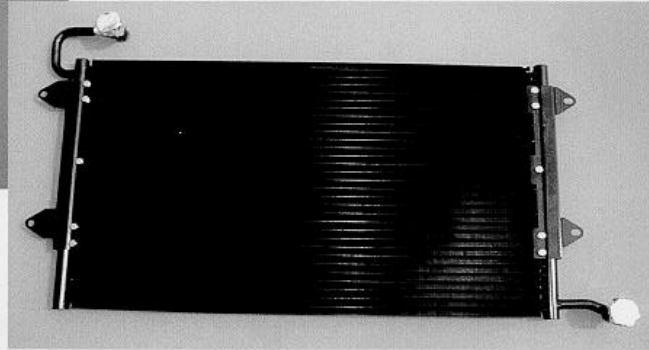

Multi-flow type, 5path

 SANDEN

Experimental evaluation of CO₂ system and the HFC-134a system in a Wind Tunnel

Phoenix, June 28-July 1, 1999

Hose

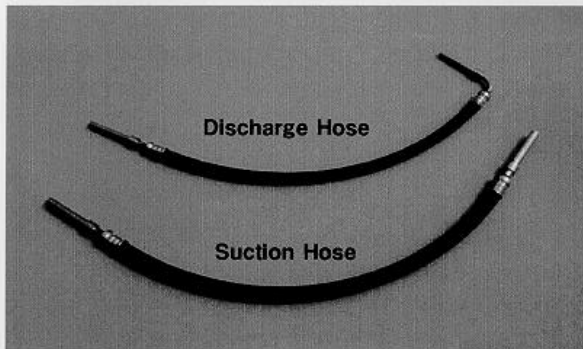

Discharge Hose

Suction Hose

1mm Nylon liner
Suction Hose I.D. ϕ 12.0mm
Discharge Hose I.D. ϕ 8.5mm

Clutch Cut Off Switch

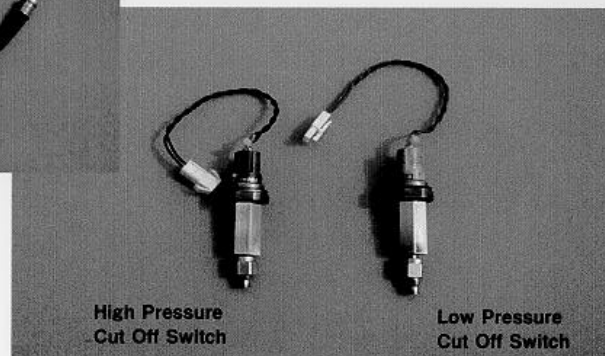

High Pressure
Cut Off Switch

[14.9MPa cut off]

Low Pressure
Cut Off Switch

[2.45MPa cut off]

 SANDEN

Experimental evaluation of CO₂ system and the HFC-134a system in a Wind Tunnel

Phoenix, June 28-July 1, 1999

High Pressure Relief Valve

Relief Pres.: 17.65 MPa Open

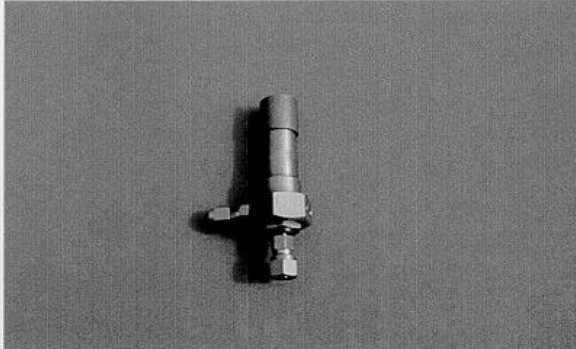

Back Pressure Controller for high pressure bypassing

Bleed Pres.: 14.2 MPa Open

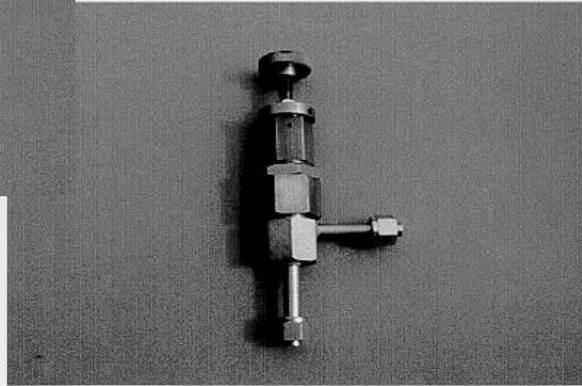

Phoenix, June 28-July 1, 1999

SANDEN

Experimental evaluation of CO₂ system and the HFC-134a system in a Wind Tunnel

Expansion Valve

(1) Constant Outlet Pressure Type

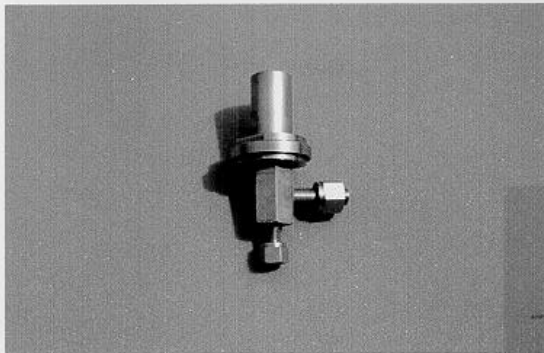

(2) Thermostatic Expansion Valve superheat control type

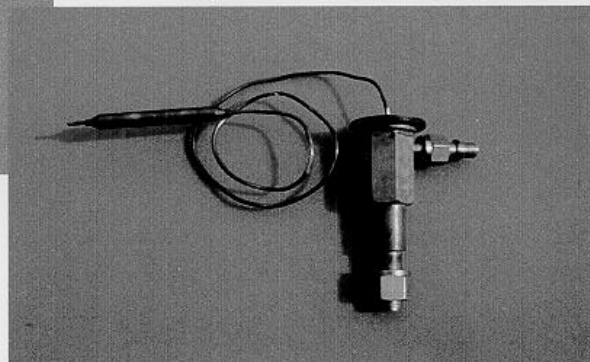

Phoenix, June 28-July 1, 1999

SANDEN

Experimental evaluation of CO₂ system and the HFC-134a system in a Wind Tunnel

6. Conclusions

- (1) A CO₂ system with constant outlet pressure type expansion valve showed excellent pull down during 32 km/h and 64 km/h modes. Performance at idle speed must be improved.
- (2) Data for a system with superheat control type expansion valve showed poor performance. The expansion valve does not seem to be functioning as expected.
- (3) A realistic approach to the CO₂ transcritical cycle mobile A/C by use of mechanical expansion control type expansion valves seems to be worth continuing.