

# HIGH-SIDE-PRESSURE OPTIMIZATION IN TRANSCRITICAL CO<sub>2</sub> CYCLES WITH WORK-EXTRACTING EXPANSION DEVICES

Hans-Joachim Huff

Yunho Hwang, Ph.D.

Reinhard Radermacher, Ph.D.



---

*University of Maryland, College Park*



Center for Environmental Energy Engineering

# “Optimum” High-Side Pressure

- Heat rejection in super-critical region
- High-side pressure independent of ambient temperature
- “Optimum” high-side pressure where COP maximum for given operating conditions (ambient temperatures, compressor RPM)

# Performance of System with Isenthalpic Throttling Process

High-side pressure adjusted with expansion valve setting

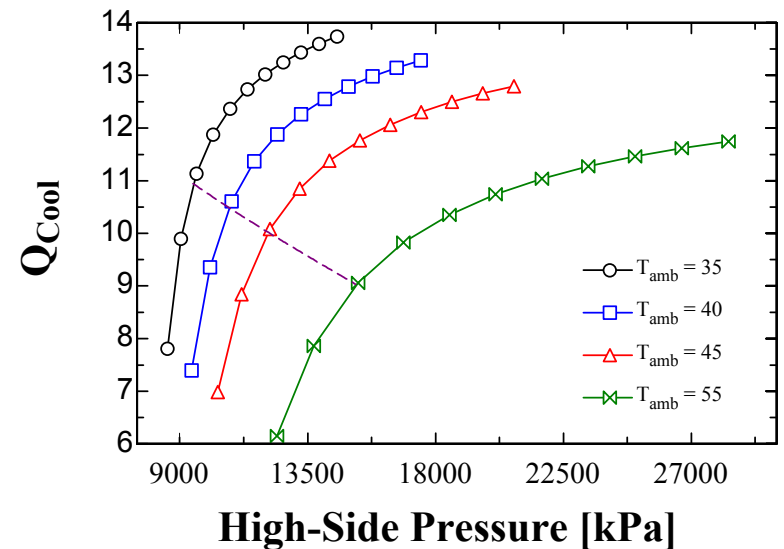
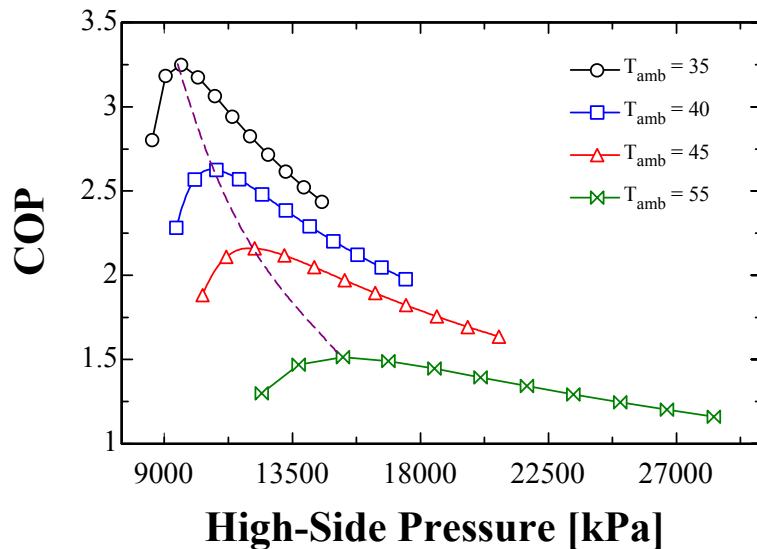

# System with Work-Extracting Expansion Device (Expander)

- Benefits:
1. Reduce net work-input to system
  2. Increase cooling capacity

Performance improvement: 30% to 65% in COP

Objective: Control strategy for maintaining optimum high-side pressure under all operating conditions

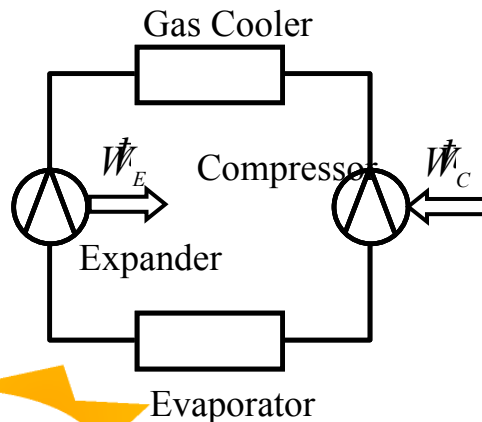

Adjust High-Side Pressure:

- Variable expander speed or displacement volume
- Additional expansion valve
  - Upstream of expander
  - Downstream of expander
  - Parallel to expander

# Options for Adjusting High-Side Pressure in Expander Cycle

Variable Expander Speed  
(or Displacement Volume)

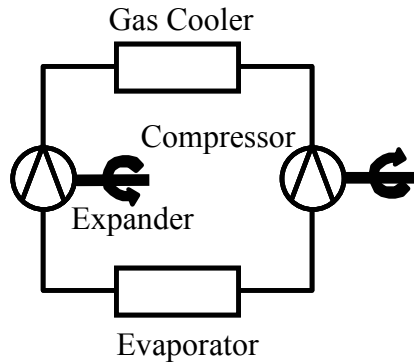

Upstream Expansion Valve

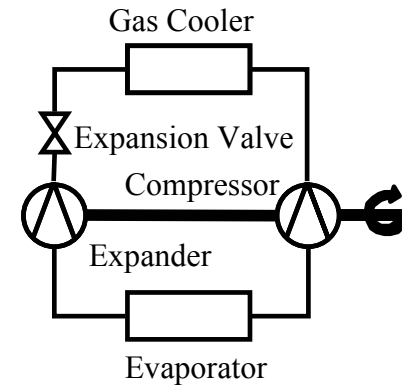

Downstream Expansion Valve

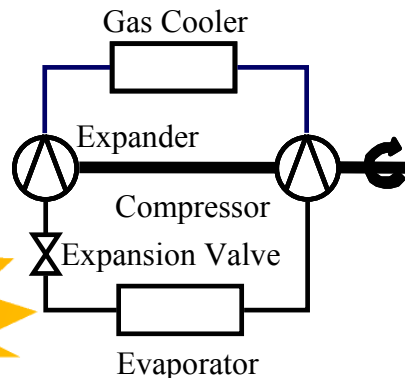

Parallel Expansion Valve

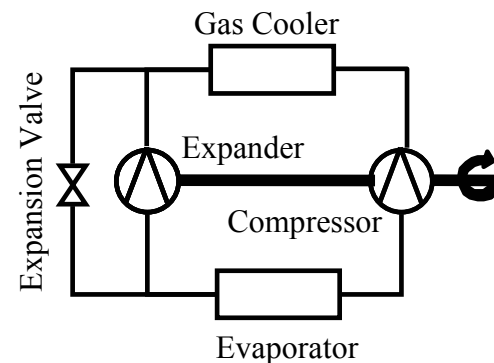

# Modeling Assumptions

- Constant volumetric and isentropic efficiency of compressor and expander
- Constant UA value for heat exchangers
- Perfect accumulator at evaporator outlet  
=> saturated vapor at evaporator outlet
- Energy balance, mass balance, and heat transfer determine high-side and low-side pressure

# Variable Expander Speed

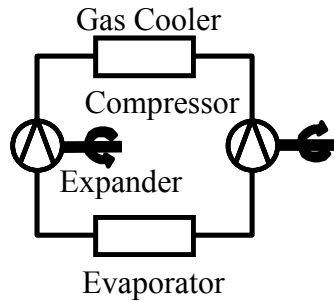

- High-side pressure adjustable
- COP can be optimized

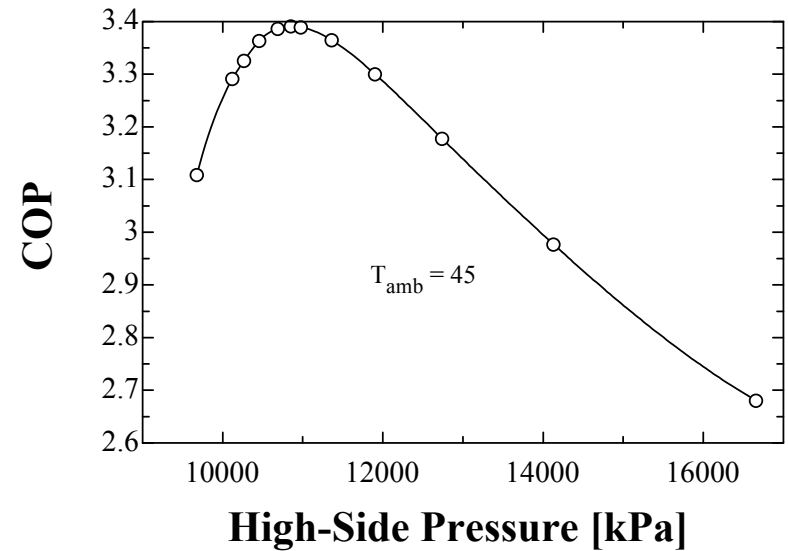
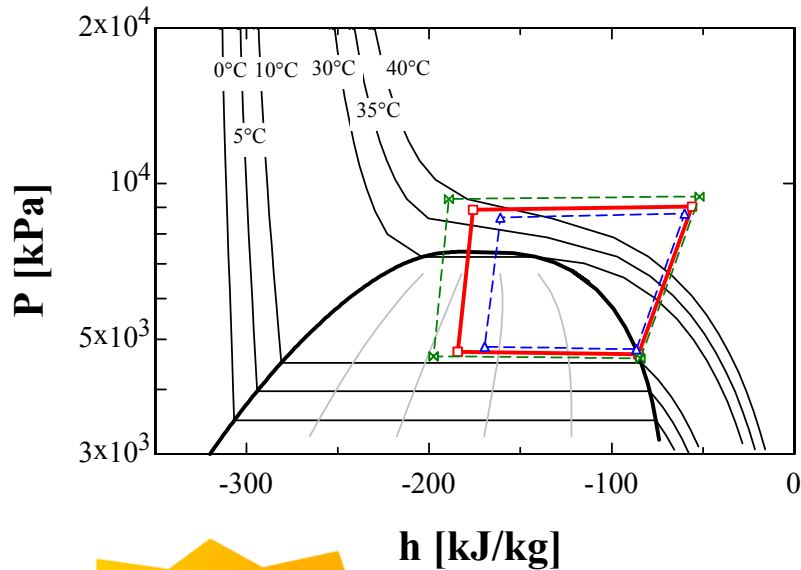

# Upstream Expansion Valve

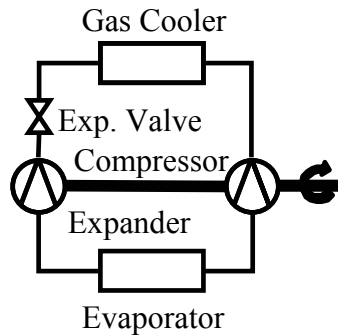

- Only increases high-side pressure
- Effect on high-side pressure small
- COP cannot be optimized

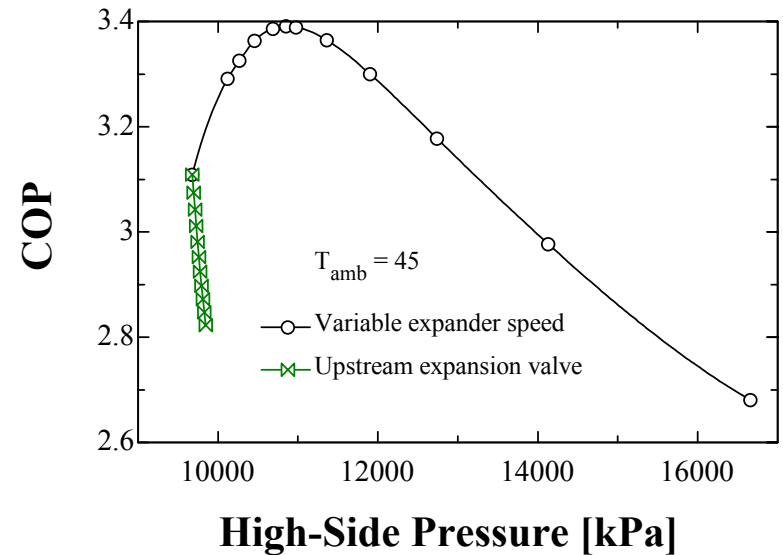
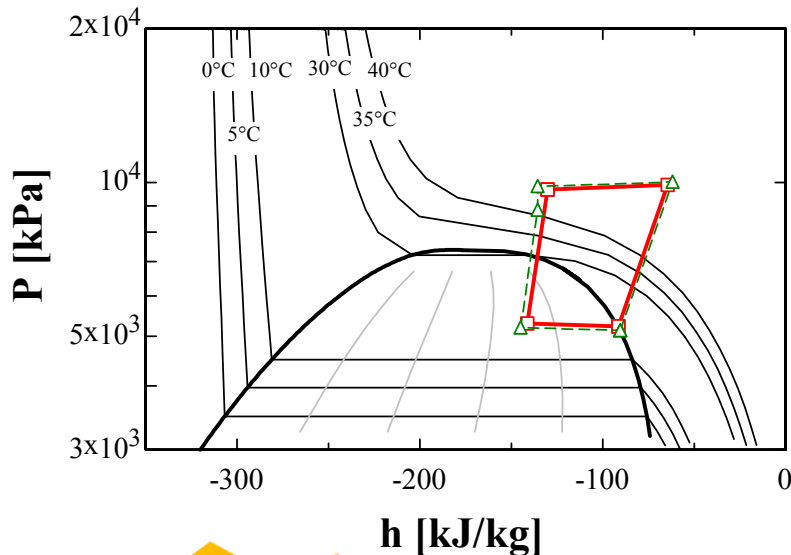

# Downstream Expansion Valve

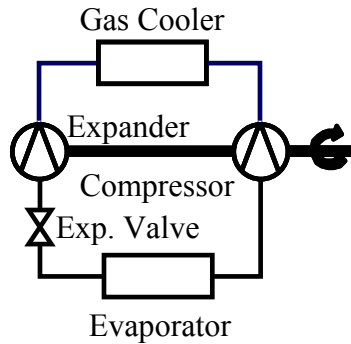

- Only increases high-side pressure
- Effect on high-side pressure small
- COP cannot be optimized

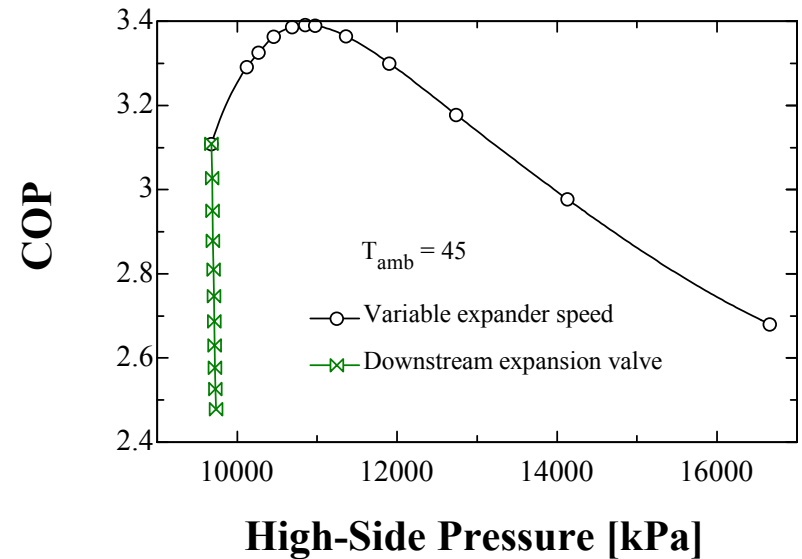
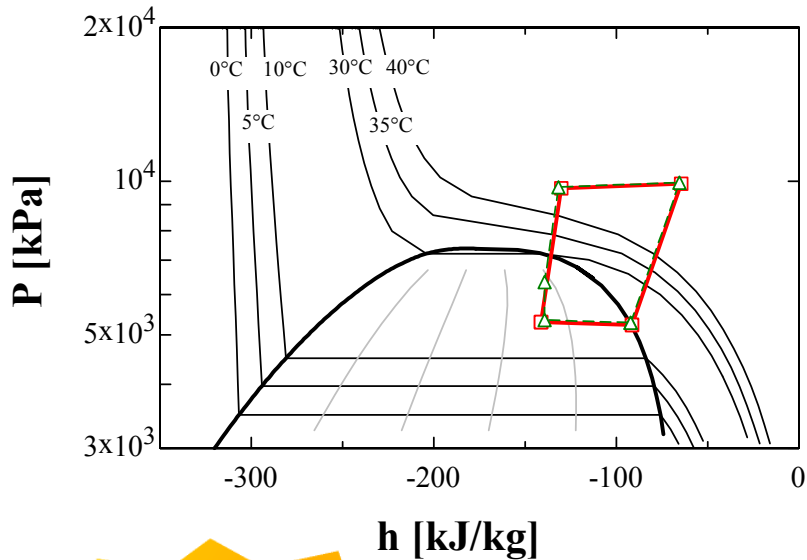

# Parallel Expansion Valve

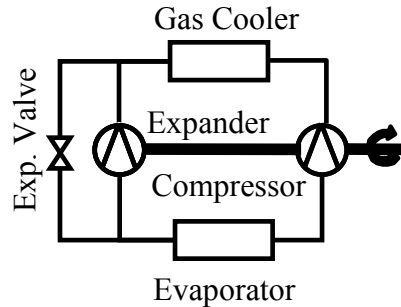

- Only reduces high-side pressure
- COP can be optimized
- Maximum COP lower than with variable expander speed

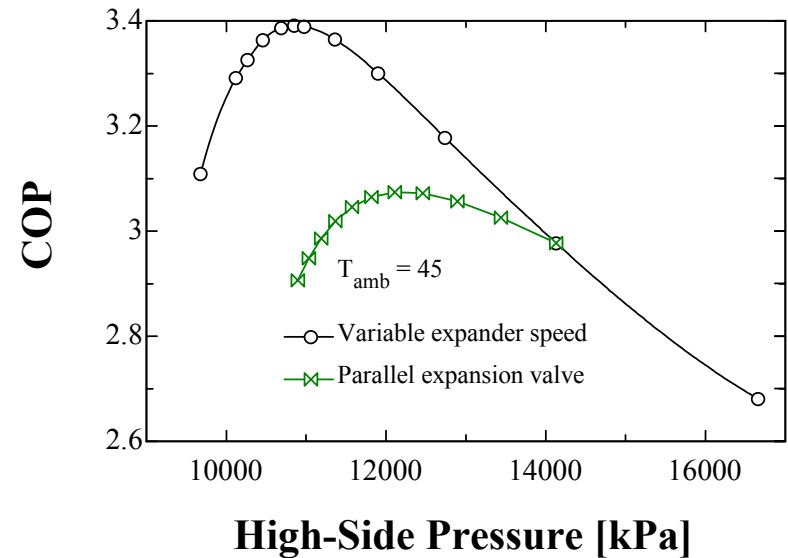
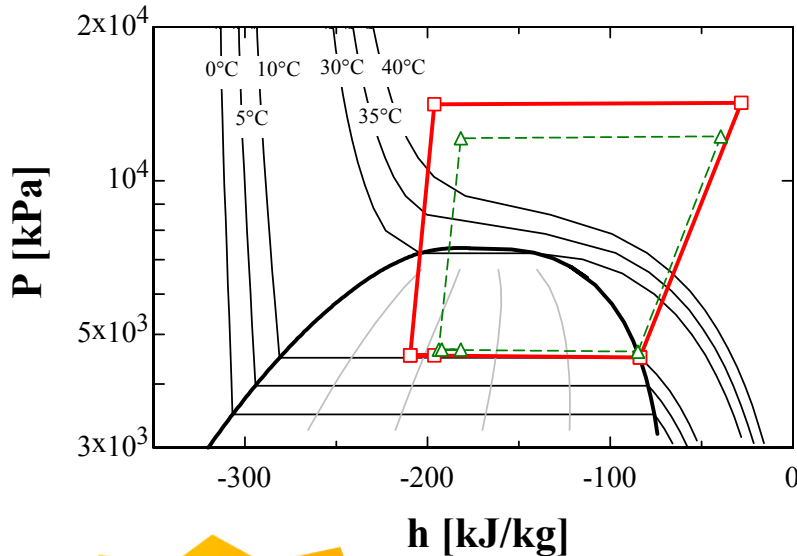

# Findings:

- CO<sub>2</sub> expander-cycle has “optimum” high-side pressure
- Options for optimizing high-side pressure:
  - Variable expander speed
  - Additional expansion valve parallel to expander
- Option of choice: variable expander speed

# Control Problem:

- How does “optimum” expander speed change with operating conditions?

# Constant "Optimum" Expander Speed

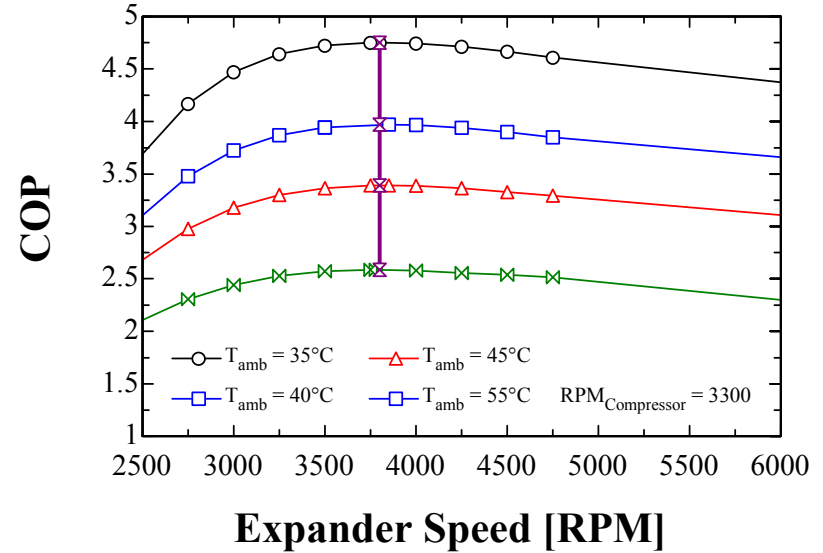
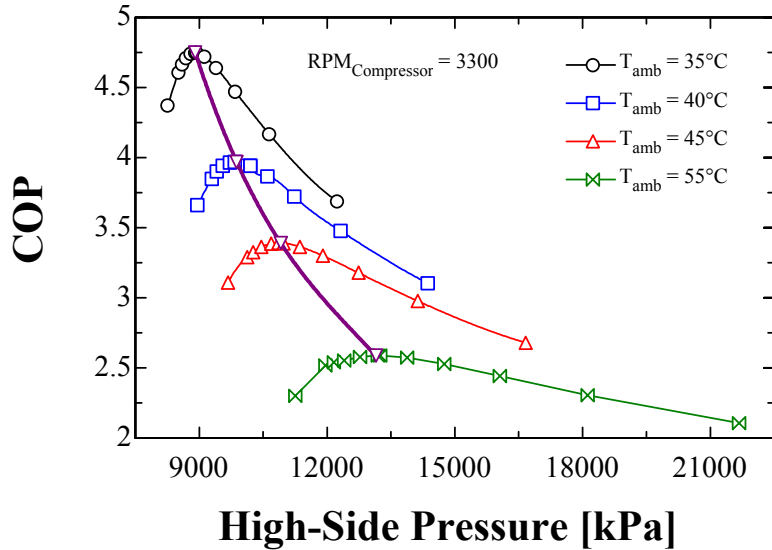

$$\dot{V}_i = \gamma_v \cdot V_{displ} \cdot RPM / 60 = \dot{m} / \rho$$

$$\dot{V}_C^{in} / \dot{V}_E^{in} \text{ for all temperatures}$$

$$\Rightarrow \frac{\rho_C^{in}}{\rho_E^{in}} = \text{constant}$$

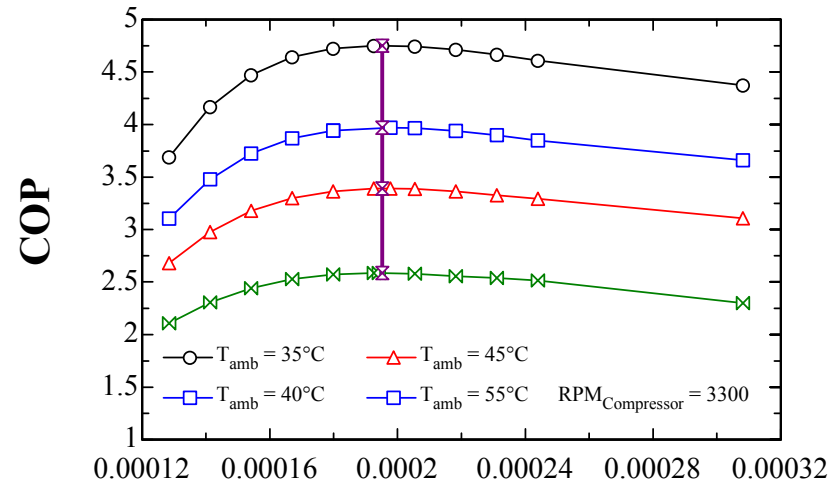

**Volumetric Flow Rate at Expander Inlet [m<sup>3</sup>/s]**

# Optimum Expander Speed at Varying Compressor Speed

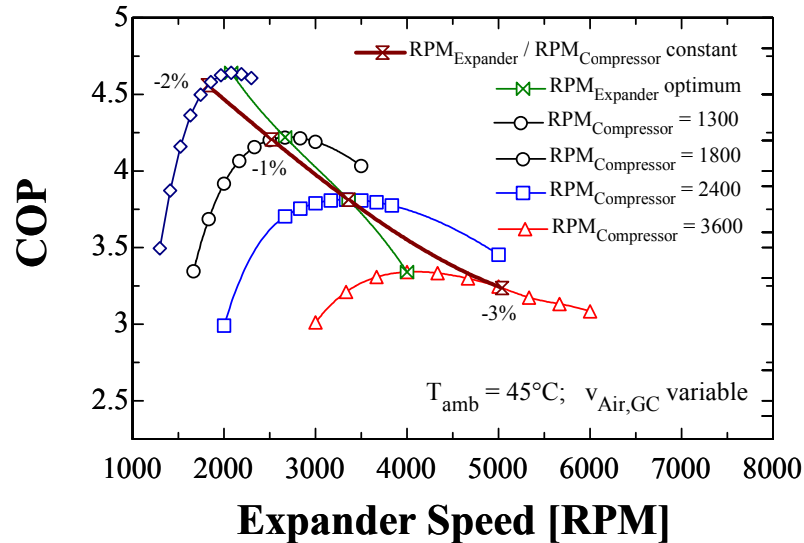

- Optimum expander speed changes with compressor RPM
- Does not change proportional with compressor speed

COP close to optimum if expander speed changed proportional to compressor speed

# Optimum Expander Speed at Varying Compressor Speed and Temperatures

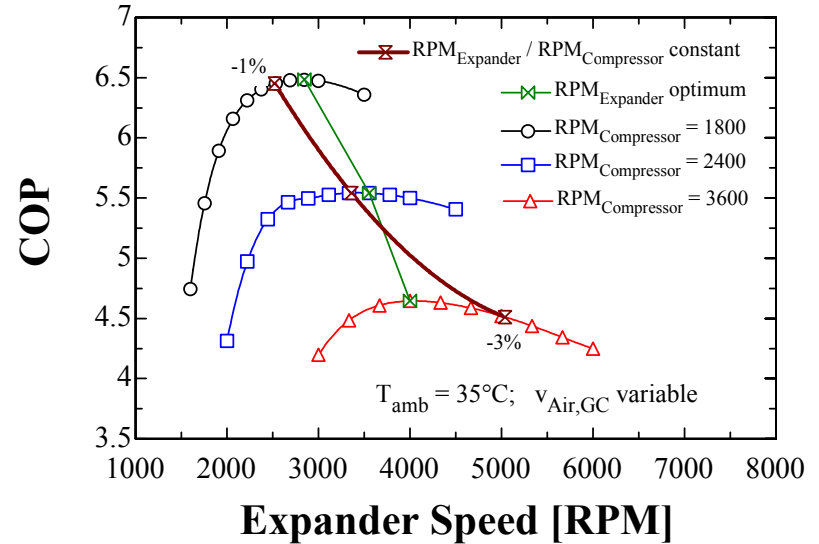
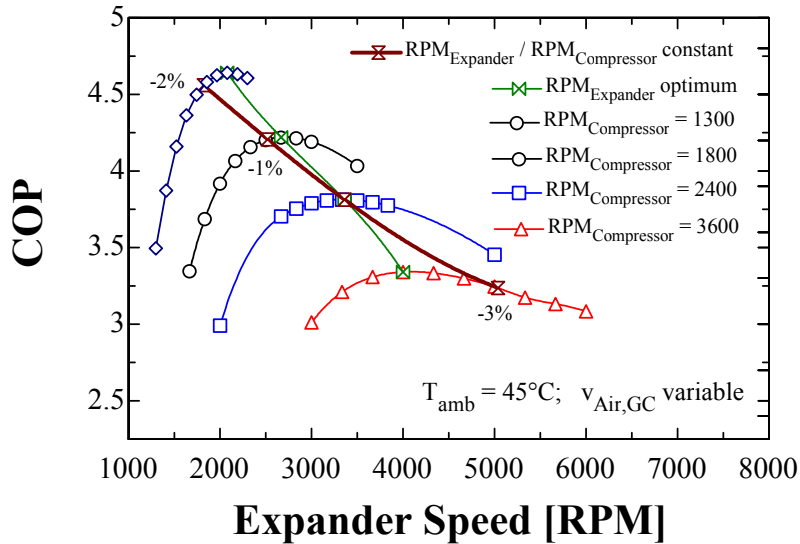

Same  $\frac{\text{Compressor RPM}}{\text{Expander RPM}}$   
 for all ambient temperatures

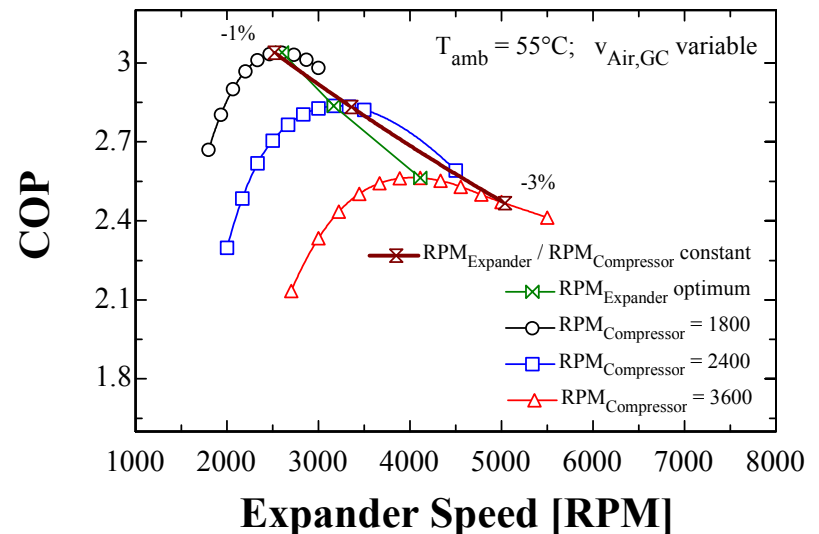

Variation of opt.  
 charge:  $\sim 20\%$

# Component Design and High-Side Pressure Control for Expander Cycle

- COP close to maximum for constant ratio of expander speed to compressor speed over wide range of compressor RPM and ambient temperatures

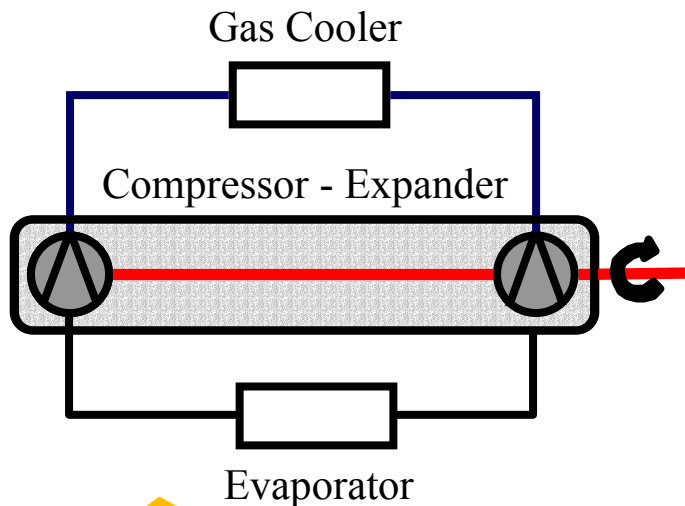

- Design optimized integrated compressor – expander with common shaft
- Minimize losses of expander work-output
- Additional high-side pressure control not necessary
- Possible penalty: Long pipe in engine compartment => heat transfer

# Future Work

- Variable heat transfer coefficients
- Include realistic accumulator
- Realistic compressor and expander performance (current work at CEEE)
  - Valve losses
  - Internal leakage
  - Internal heat transfer
  - Different compressor and expander types
- Optimize compressor – expander coupling

# Conclusions

1

- High-side pressure can be optimized with variable expander speed or expansion valve parallel to expander
- Variable expander speed gives best performance
- Optimum expander speed independent of ambient temperature at constant compressor speed
- Optimum expander speed dependent on compressor speed, but not proportional

- COP near optimum for wide range of operating conditions with suitable constant ratio of expander speed to compressor speed
- Match optimum expander speed with compressor speed by optimizing displacement volumes
- Design integrated compressor – expander device
  - Minimize transformation losses of expander work
  - Minimize space requirement
  - Minimize weight