



Improved Fastener Removal: Handheld EDM



Michael T. Gibbons, PE
Mgr, Control Systems Development
Perfect Point EDM Corp.
mtg@ppedm.com

Department of Defense Maintenance Symposium
Great Ideas Competition, 13 Nov 2012



The Technical Problem

Removing aerospace fasteners by conventional drilling:

- Slow, especially on hard metals
- High damage rate
- Ergonomic risk exposure
- Generates large quantities of sharp metallic FOD





The e•drill Solution

- World's first handheld EDM process:
US Patent No. 8,178,814 B2
- Align e•drill to target fastener, center ground pin makes contact with fastener head
- Cutting electrode advances and spark-erodes a circular cut groove into the fastener head
- De-ionized water flushes cut zone, keeping part cool and removing cut debris
- Once cut is complete, remaining metal fillet is punched out

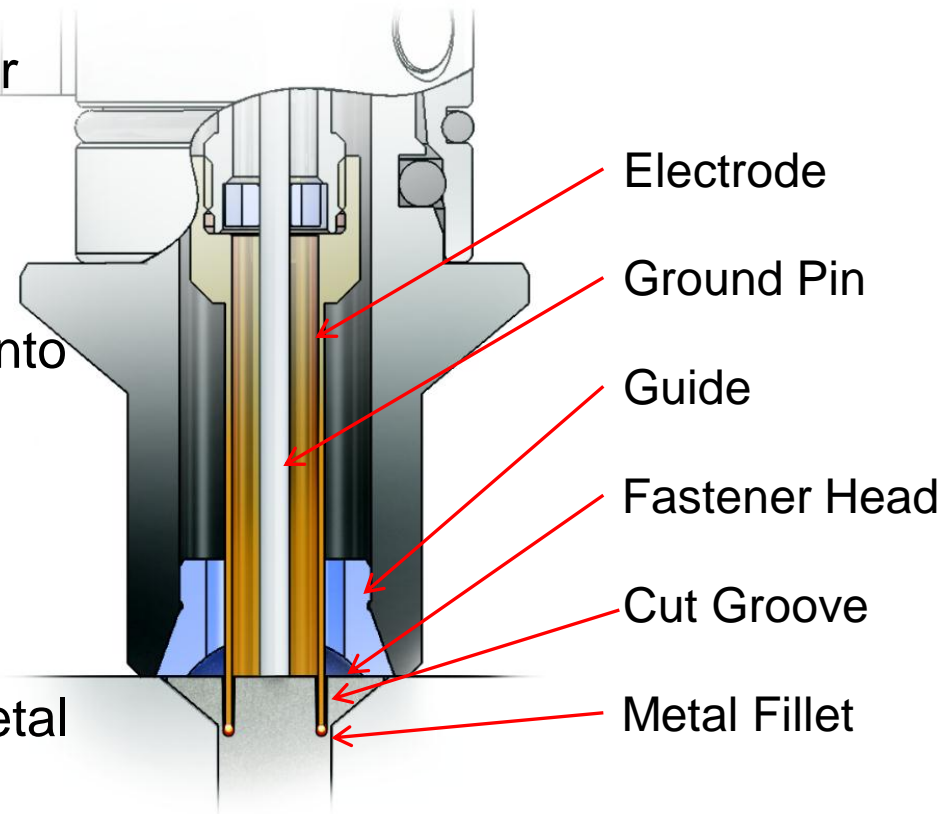



The e-drill in action



Aerospace Fastener Removal:
Button Head Application

Works on:
Button Head
Flush Head
Collar Side

Sizes:
3/32" – 3/8"

Types:
Hi-Lok[®]
Jo-Bolt[®]
Composi-Lok[®]
Huck Bolt[®]
CherryMAX[®]
CherryLOCK[®]
Taper-Lok[®]



The e-drill in use

- Straightforward setup and operation
- Limited user maintenance required
- Risks:
 - Concentric and perpendicular alignment is key
 - Like a standard drill, it is possible to misuse the tool





e•drill Implementation

- Extensive commercial use, limited DoD adoption
- Robins AFB, C-130 Wing Box: 3/16" Alloy Steel Taper-Lok
 - 5-10X faster than conventional drilling
 - 90% or better reduction in damage rate
- Lockheed Palmdale, F-22 Inlet Ducts: 1/4" Titanium Hi-Lok
 - Existing 20% damage rate was reduced to 0.01%
 - Labor savings: 14 shifts reduced to 4
- FRC-SW, F-18 Center Barrel Replacement: 3/16" & 1/4" Ti Hi-Lok
 - Featured in FRC-SW *Almanac*, March 2012
 - 2-day job reduced to 1/2 day
 - Estimated \$175K per year in labor savings

Technology Status

- Commercialized **e•drill** system is roughly 3 yrs old:
 - Product debut November 2009, first units shipped Q1 2010
 - Approximately 45 systems currently in use
- Likely Deployment within DoD:
 - Initial locations are Depot level Mx operations
 - Ruggedized packaging is in development
- Possible obstacles:
 - Long procurement cycles
 - Redundant efforts for Engineering analysis/approval
- Expect similar or better results as in the commercial sector
- We are currently unaware of any competing technologies





Vision: e•drill technology can assist the DoD mission requirement to do more with less

- NCMS/Perfect Point **FRITA** Project
 - Objective: streamline adoption of e•drill technology within DoD
 - Team includes US Navy, Air Force and Army
 - Deliverables include unified Process & Engineering specifications, as well as training/certification package
 - Specific focus on technical analysis of potential damage, with solutions for mitigation and repair



Thank You, any questions?



NOTE: The use of the photographs and logos contained in this presentation does not imply endorsement of the e•drill by FRCSW, the US Navy or the Department of Defense.