

Estimation of Target Crashes and Safety Benefits for Different Phases of Countermeasure Intervention

Wassim G. Najm

Crash Avoidance and Advanced
Safety Systems Division

“This is a work of the U.S. Government and is not subject to copyright in the United States; it may be used or reprinted without permission”



John A. Volpe National Transportation Systems Center
U.S. Department of Transportation

Presentation Outline

- Introduction
- Crash Prevention
- Crash Severity Reduction
- Crash Injury Mitigation
- Concluding Remarks



Crash Scenarios and Countermeasures

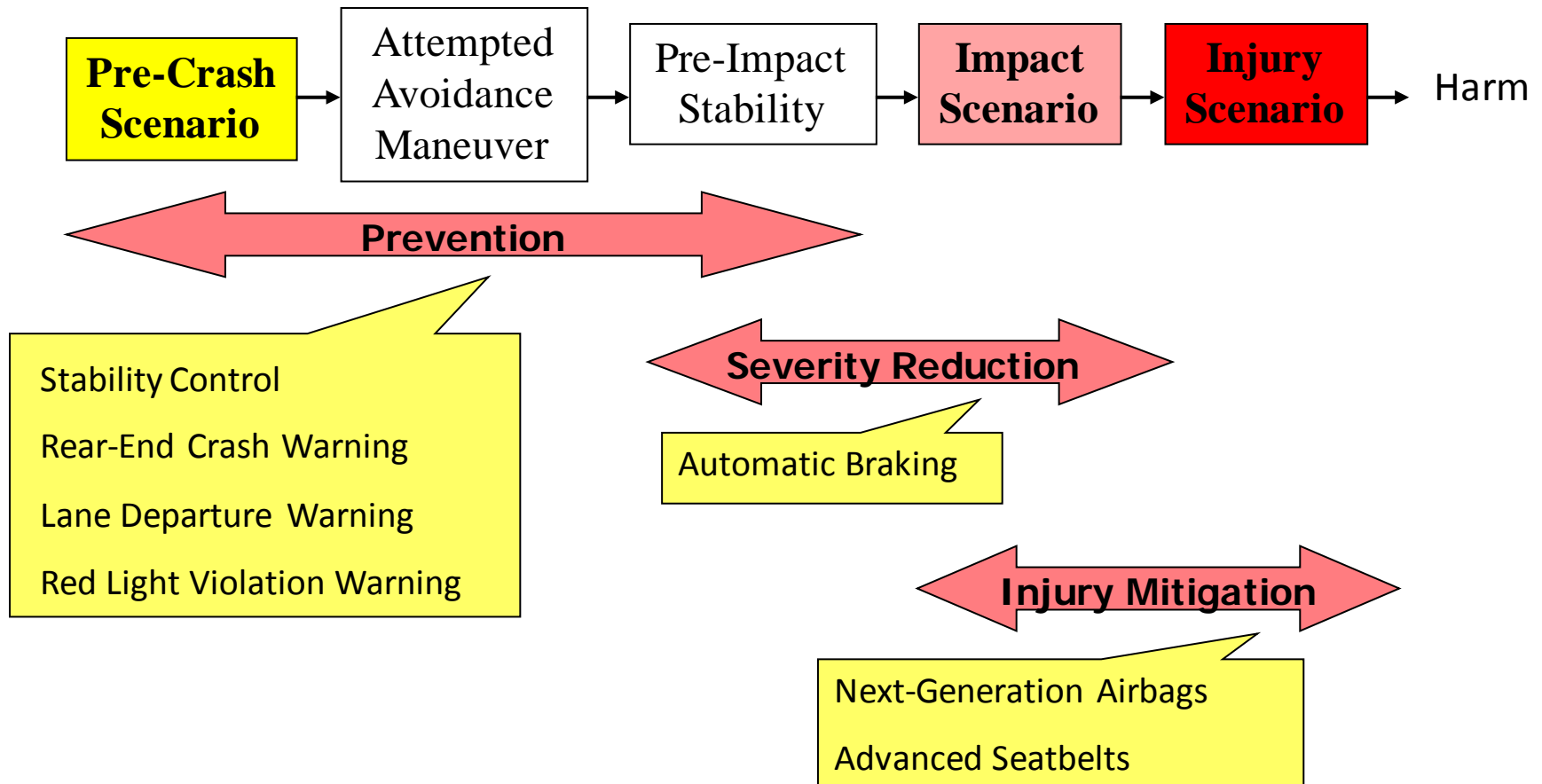

Crash Analysis and Benefits Estimation

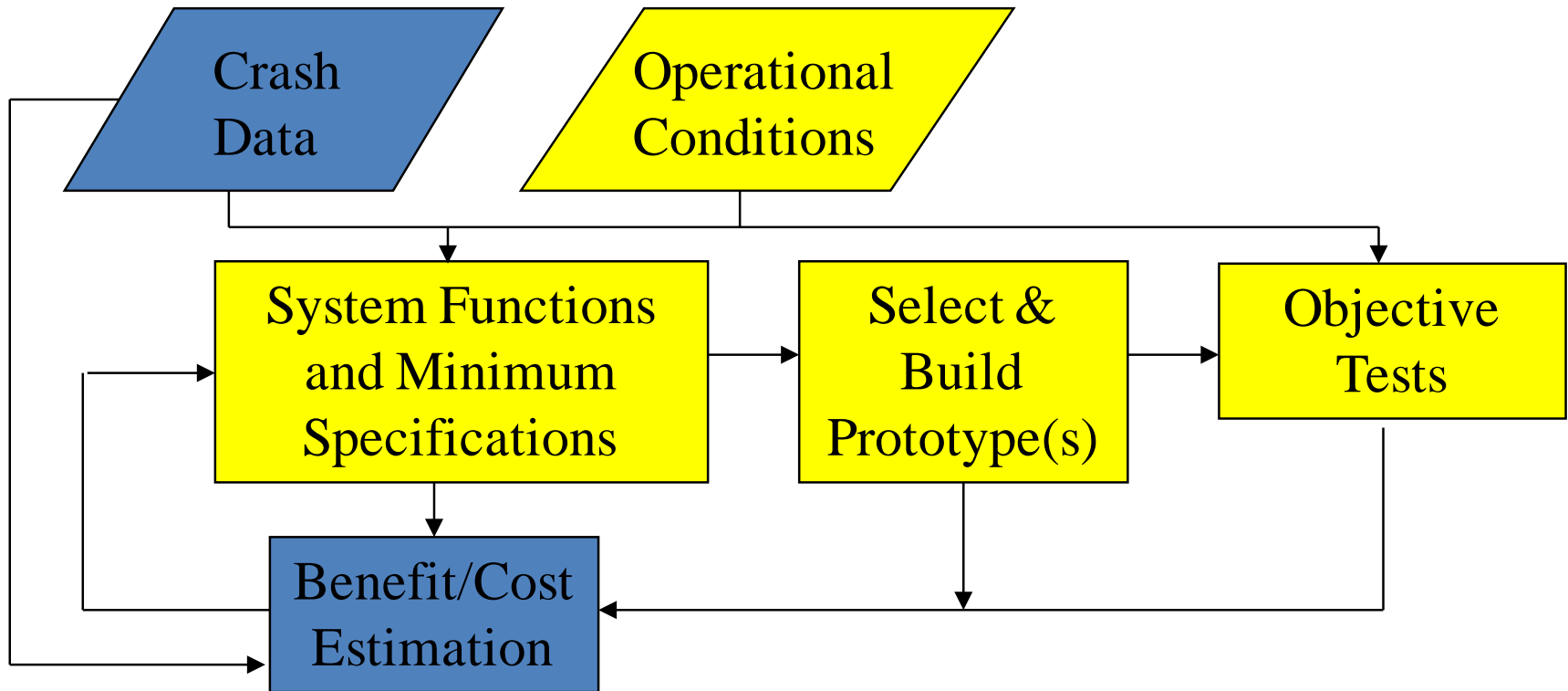

Crash Analysis Framework

Top-Down Analysis

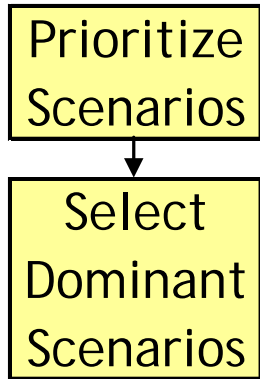

Bottom-Up Analysis

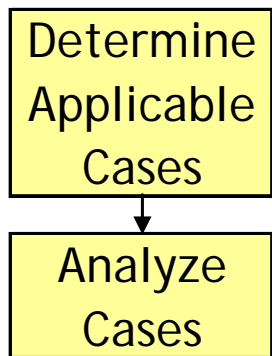

Breakdown of Crash Types

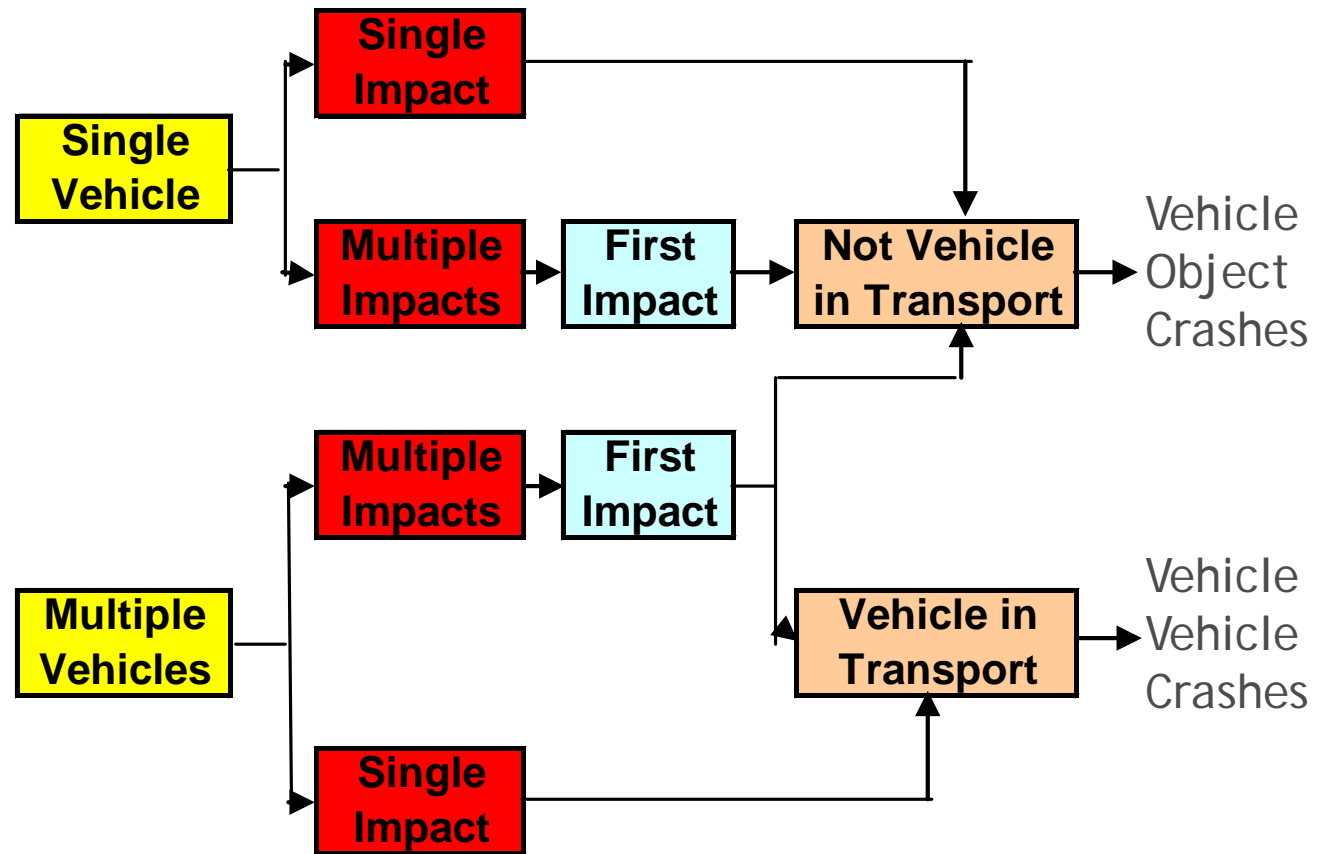

Safety Benefits Estimation

$$\text{Harm Reduction} = H_{wo} - H_w = H_{wo} \times SE$$

- H_{wo} and H_w : Total harm without and with countermeasure intervention
- SE: Countermeasure effectiveness in reducing harm

Harm Measures:

- No. crashes
- No. persons/body regions injured at MAIS 2+ or 3+
- Value of statistical life
- Functional years lost

MAIS: Maximum Abbreviated Injury Scale



Harm Values

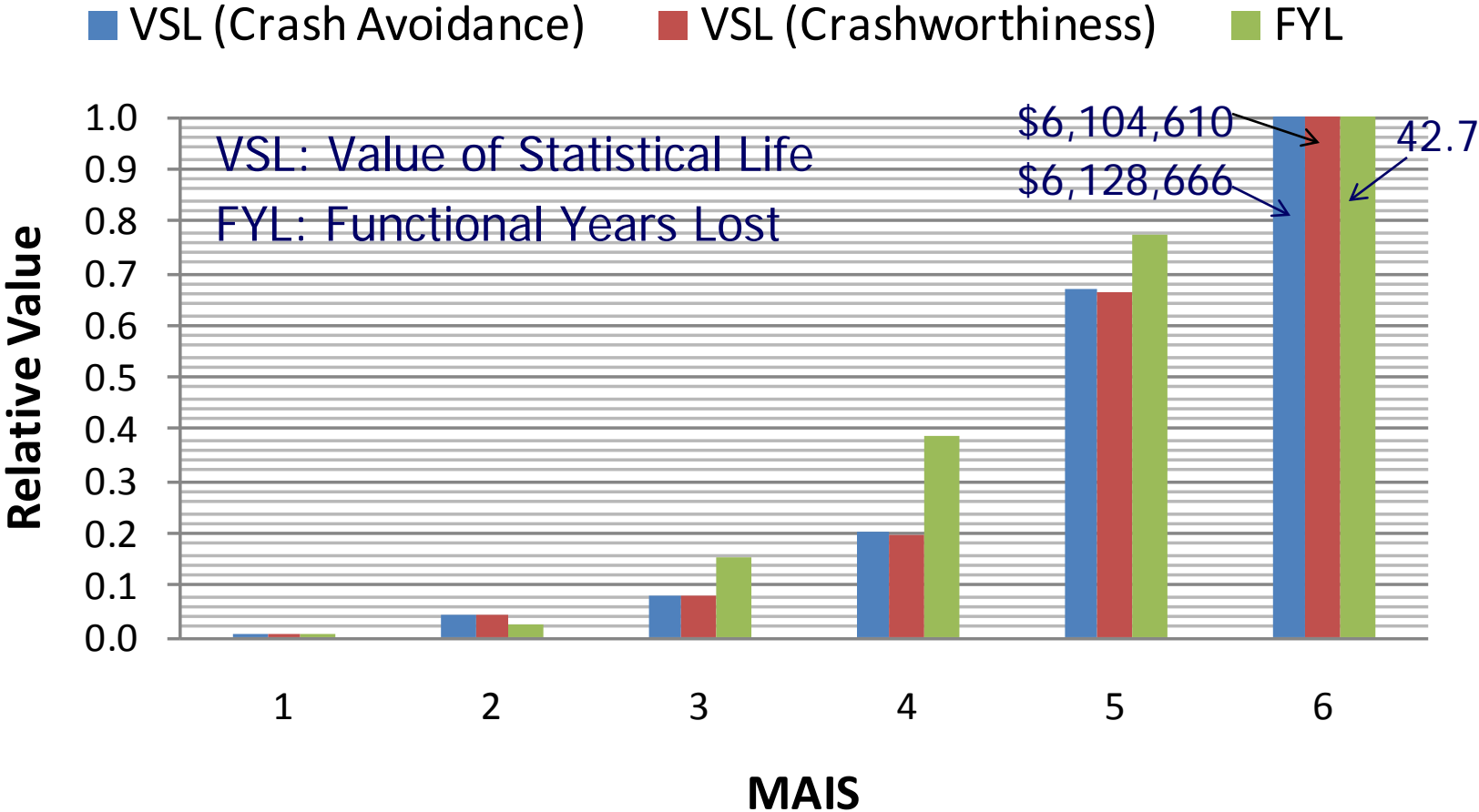

Crash Prevention: Pre-Crash Scenarios

Proportion

0% 6% 12% 18%

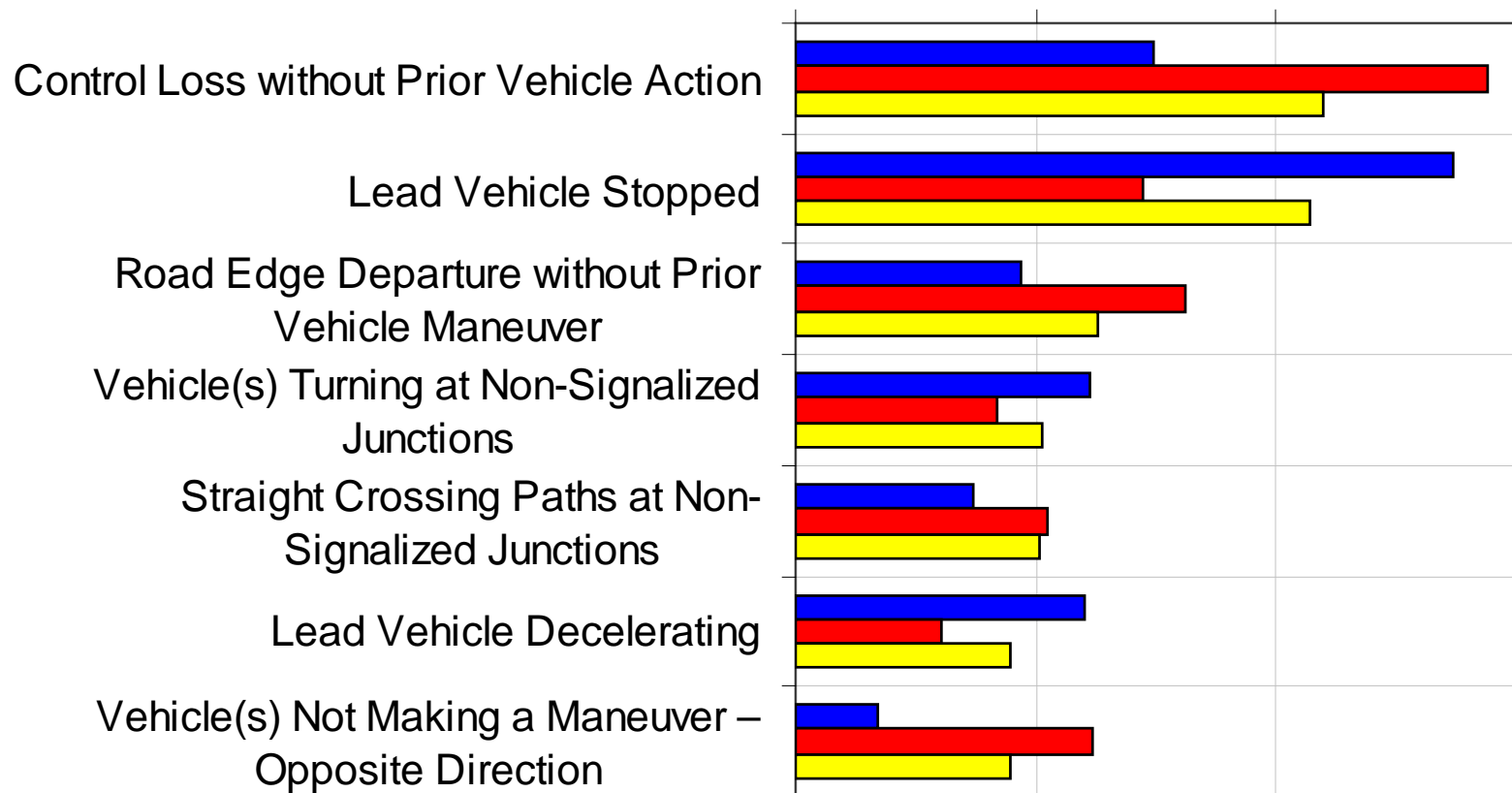

■ Frequency ■ Functional Years Lost ■ Economic Cost



Crash Prevention: Benefits Estimation

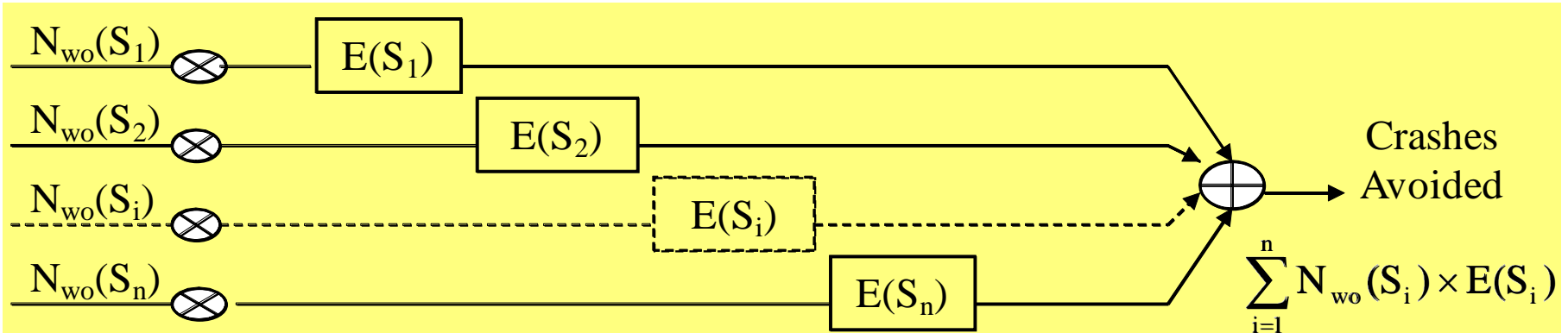

n : Number of pre-crash scenarios, S_i

$N_{wo}(S_i)$: Annual number of baseline crashes preceded by S_i

$E(S_i)$: System effectiveness in avoiding crashes preceded by S_i

Crash Prevention: Benefits Estimation

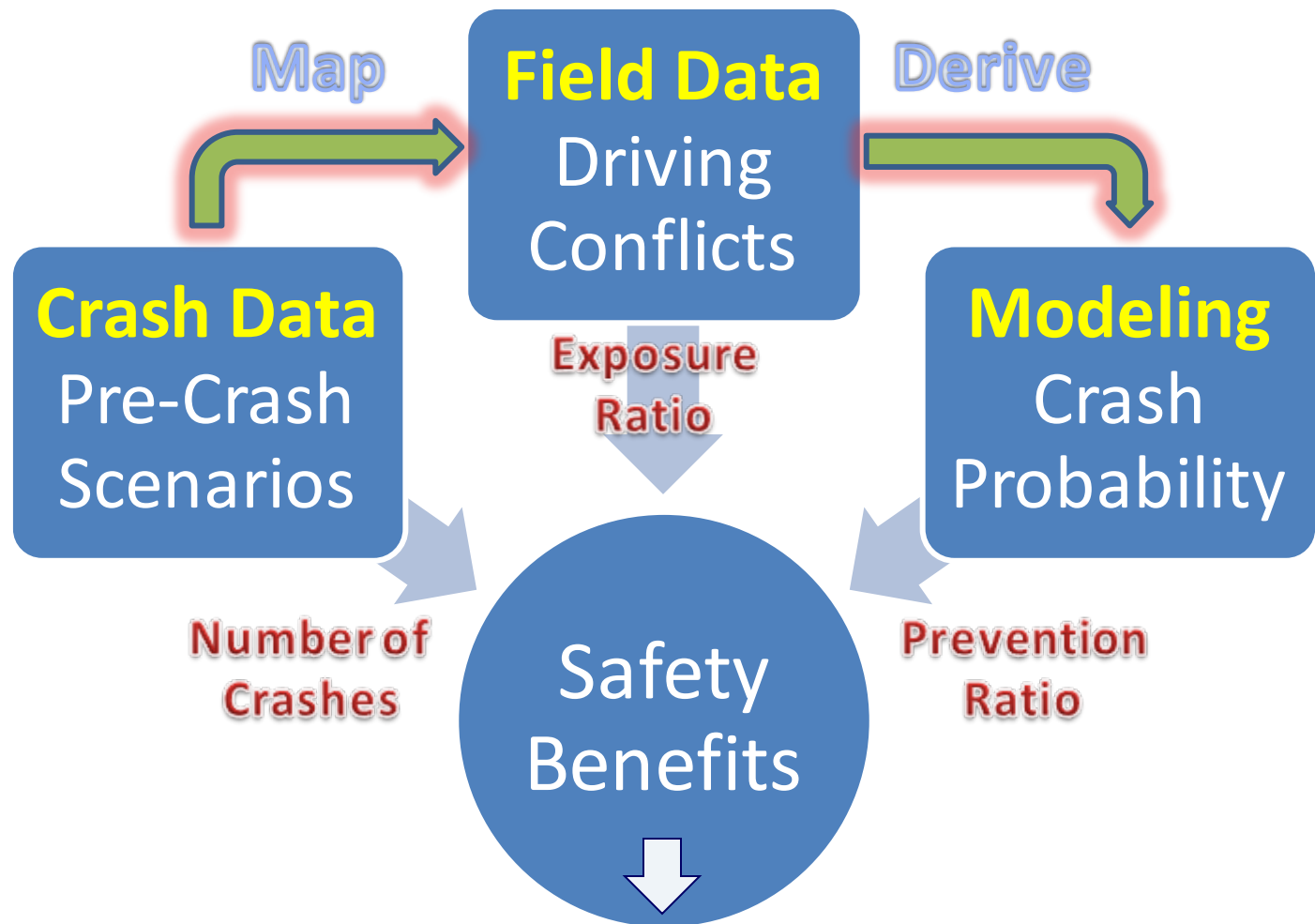

$$\text{No. crashes} \times \{1 - \text{exposure ratio} \times \text{prevention ratio}\}$$

Severity Reduction: Target Crashes

Target Vehicles:

- Light vehicles of model year ≥ 1998 with frontal damage from first impact (most harmful event)

Target Occupants:

- All occupants in target vehicle and all other persons involved in the crash
- MAIS levels 2 through 6

Crash Imminent Braking:

- No braking
- No Control loss



Injury Mitigation: Target Crashes

Target Vehicles:

- Light vehicles of model year ≥ 1998 with frontal damage from first impact (most harmful event)

Target Occupants:

- Driver and front seat passenger ≥ 13 years old in target vehicles
- MAIS levels 3 through 6
- Head and thorax MAIS 3+, and lower limbs MAIS 2+

Advanced Restraints:

- Restrained target occupants



Crash Severity and Injury Mitigation: Target Vehicle-Object Scenarios

Crash Scenario Ranking

Road Departure
Pre-Crash Scenario

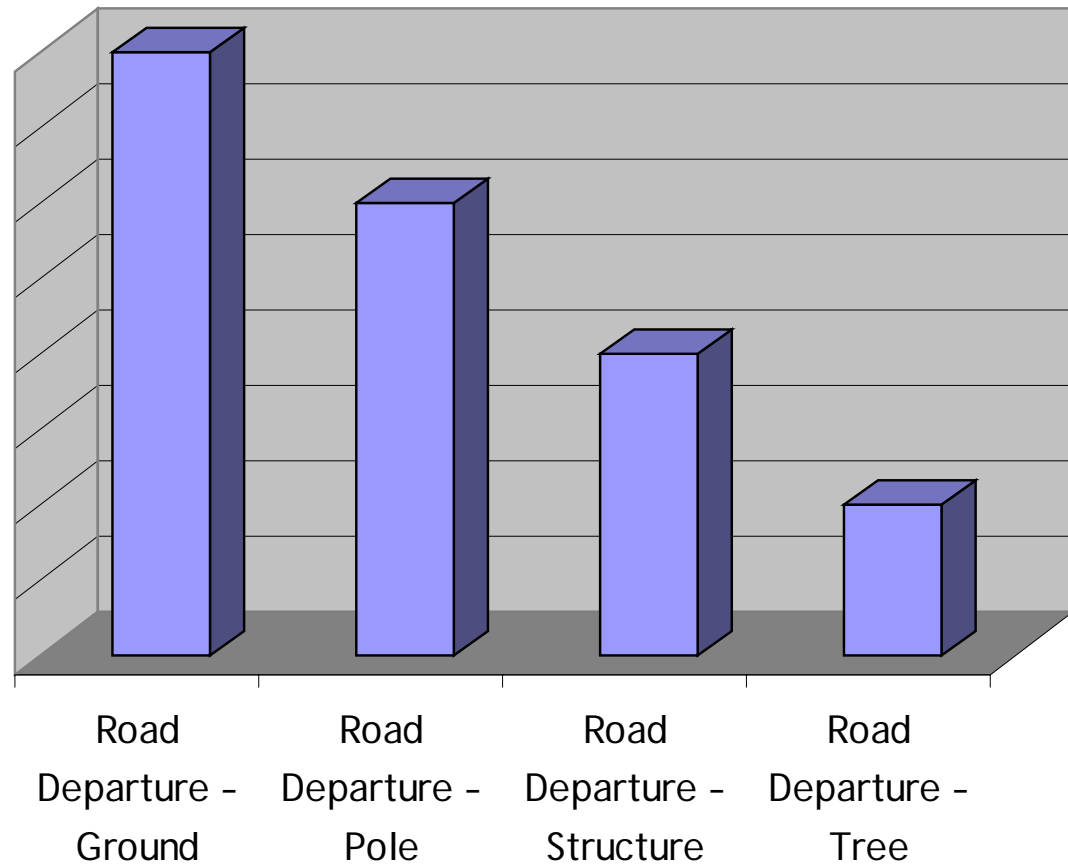
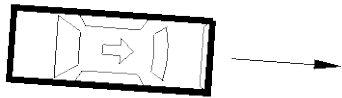

Crash Severity and Injury Mitigation: Target Vehicle-Vehicle Scenarios

LTAP/OD Pre-Crash Scenario

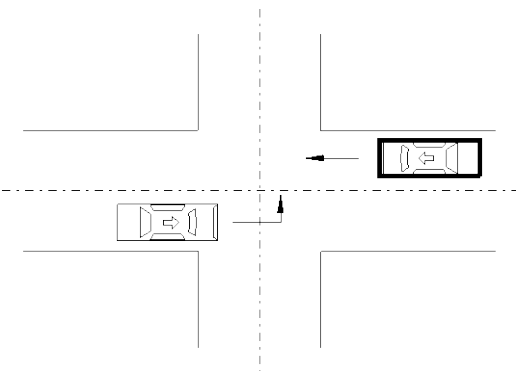

SCP Pre-Crash Scenario

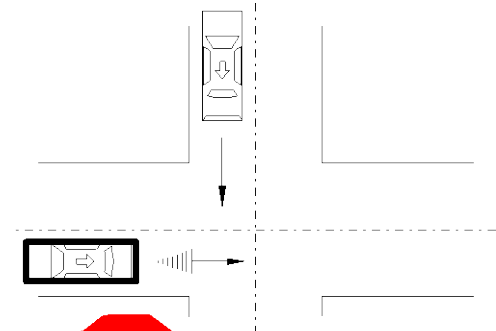

Crash Scenario Ranking

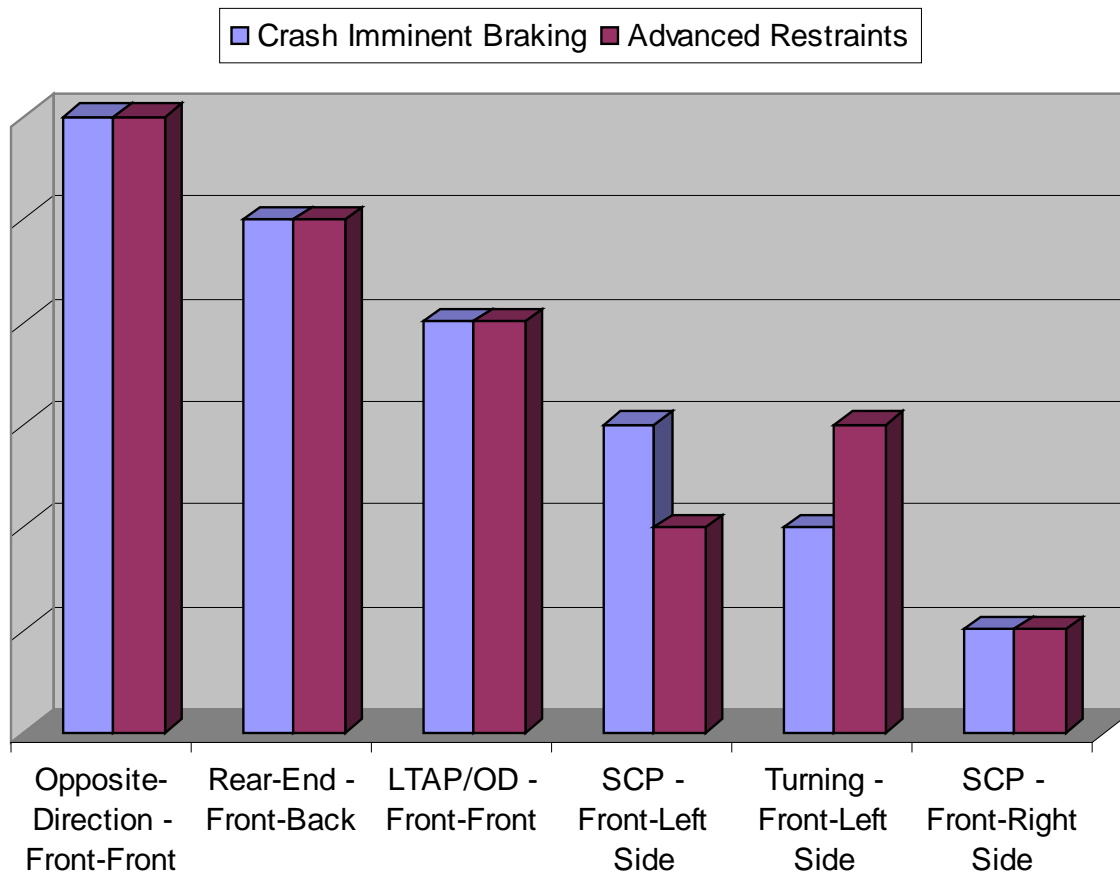

Severity Reduction: Benefits Estimation

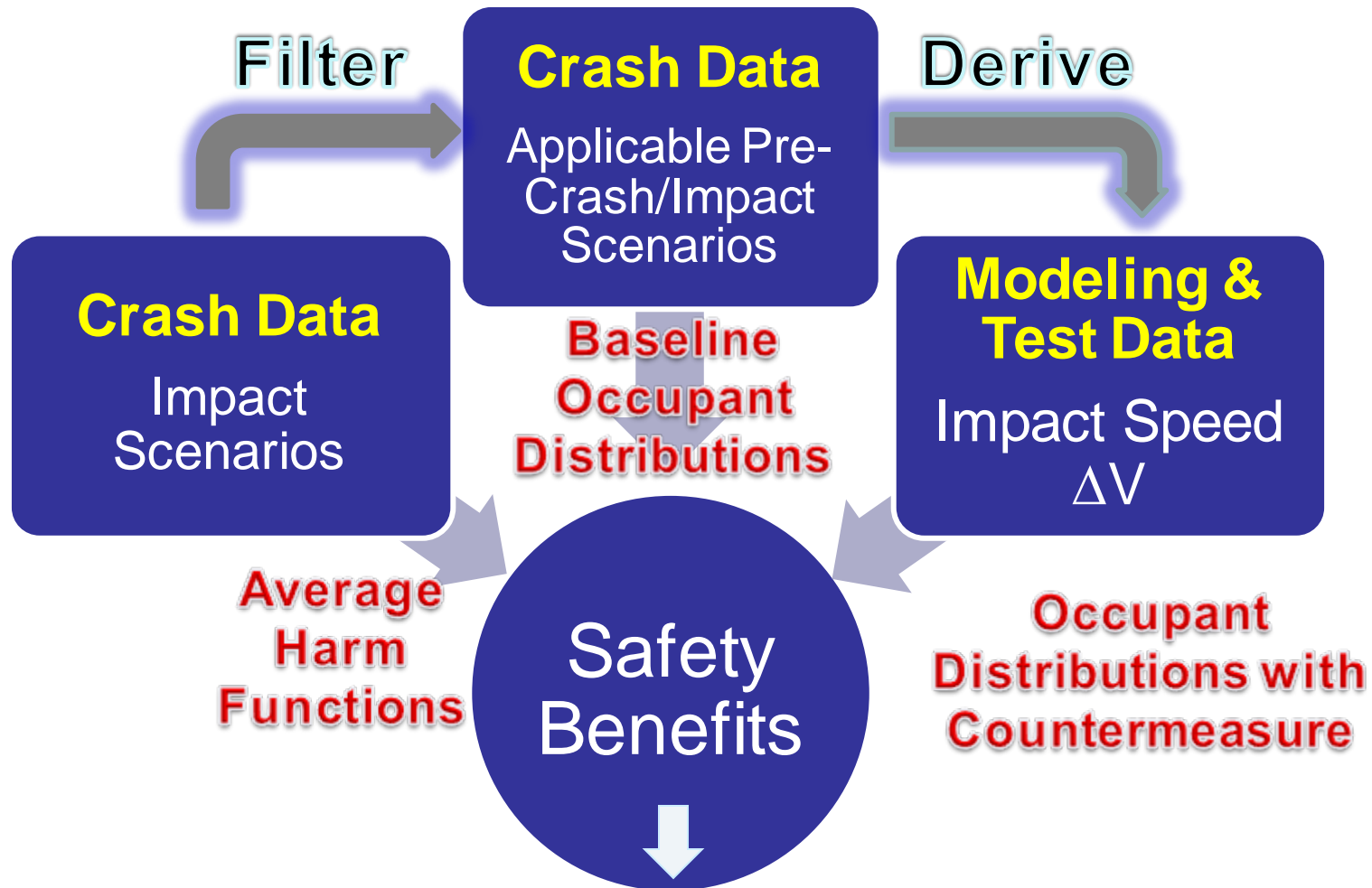

$$\{ \text{Avg. harm} \otimes \text{Bas. Occp. Dist.} - \text{Avg. harm} \otimes \text{CM Occp. Dist.} \}$$

Injury Mitigation: Benefits Estimation

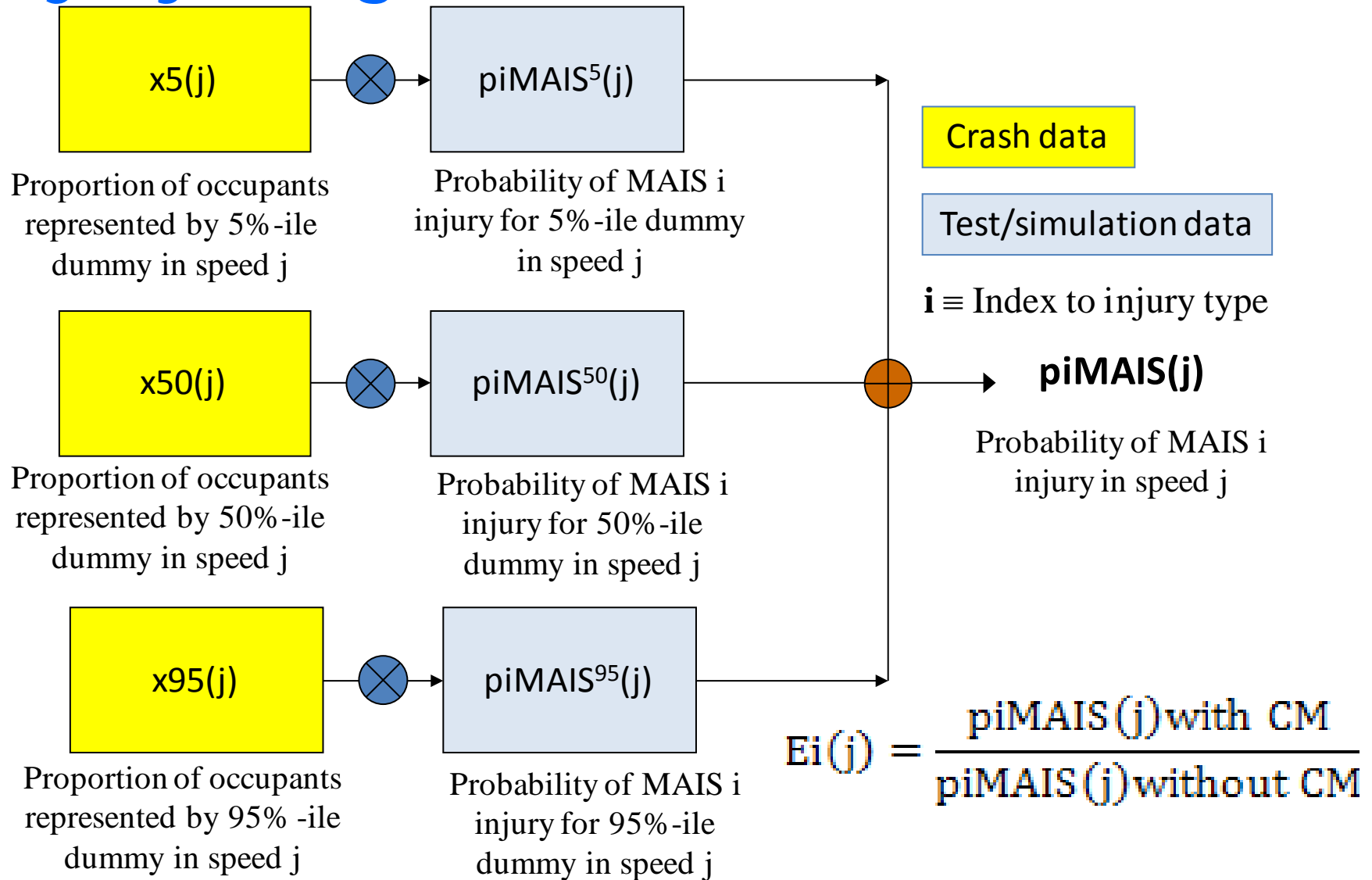

Concluding Remarks

Estimation of target crashes and safety benefits for different countermeasures is underway in a number of U.S. DOT-sponsored projects:

- Advanced Crash Avoidance Technologies (ACAT) program
- IntelliDriveSM Vehicle-to-Vehicle (V2V) Communications Safety
- Integrated Vehicle Based Safety System (IVBSS)
- Vehicle Safety Communications – Applications (VSC-A)
- Pre-Crash Sensing Crash Imminent Braking (CIB)
- Pre-Crash Sensing Advanced Restraint Systems (ARS)
- Other projects

