

Development of an Engine Anti-Ice Protection System using Experimental and Numerical Approaches

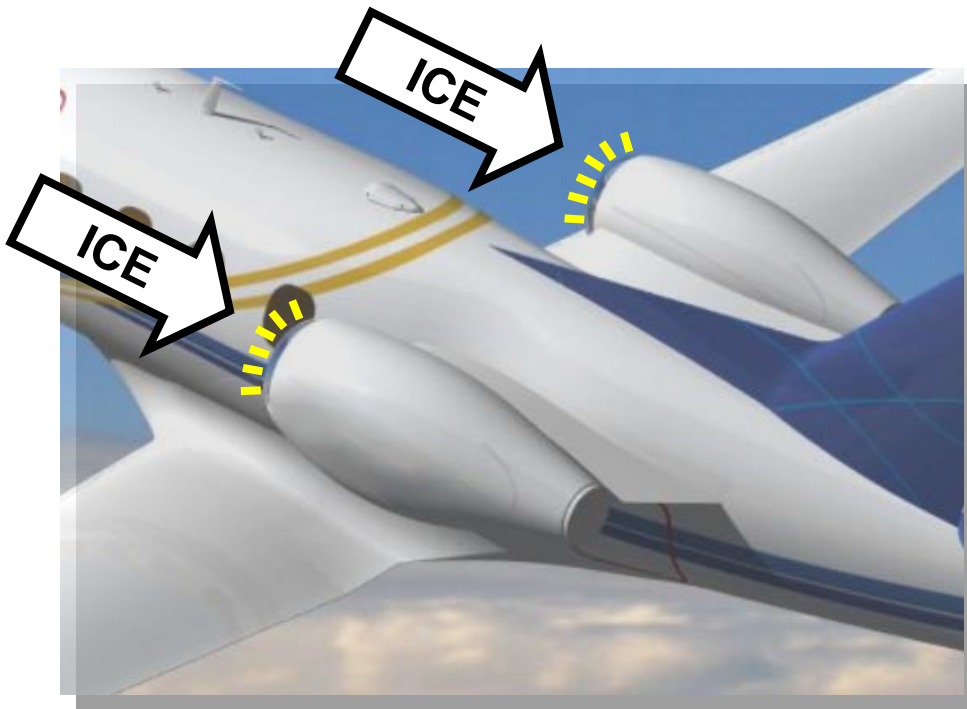

Rodrigo Hoffmann Domingos
Marcelo Pustelnik
Luís Gustavo Trapp
Guilherme Araújo da Silva
William Campo
Luis Carlos de Castro Santos

- **Show an example of how the design process of an Engine Inlet Hot-Air Anti-ice System may be done**
- **Brief description of numerical tools for thermal analysis of anti-ice systems**
- **Discuss about the techniques adopted on the design process**

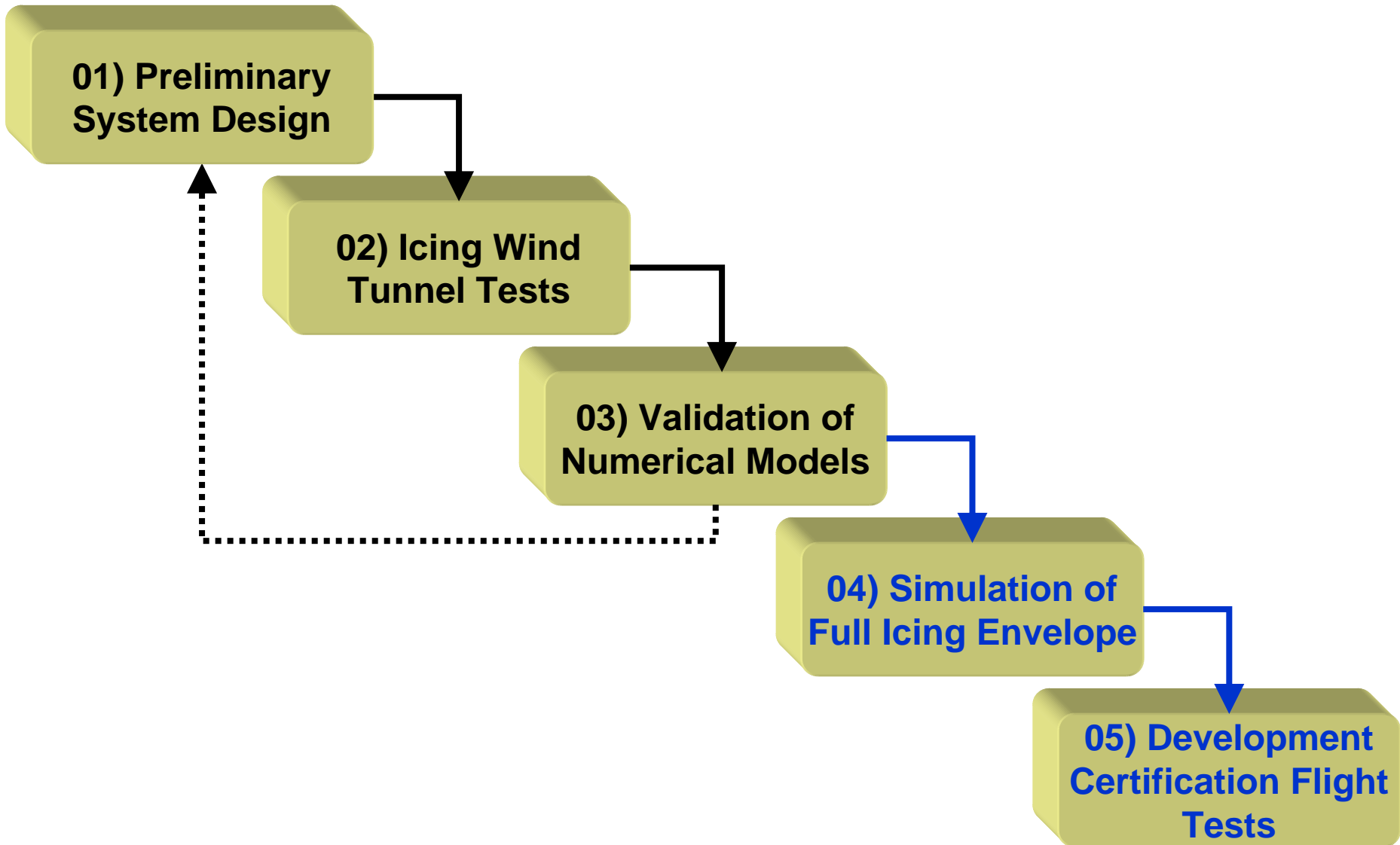

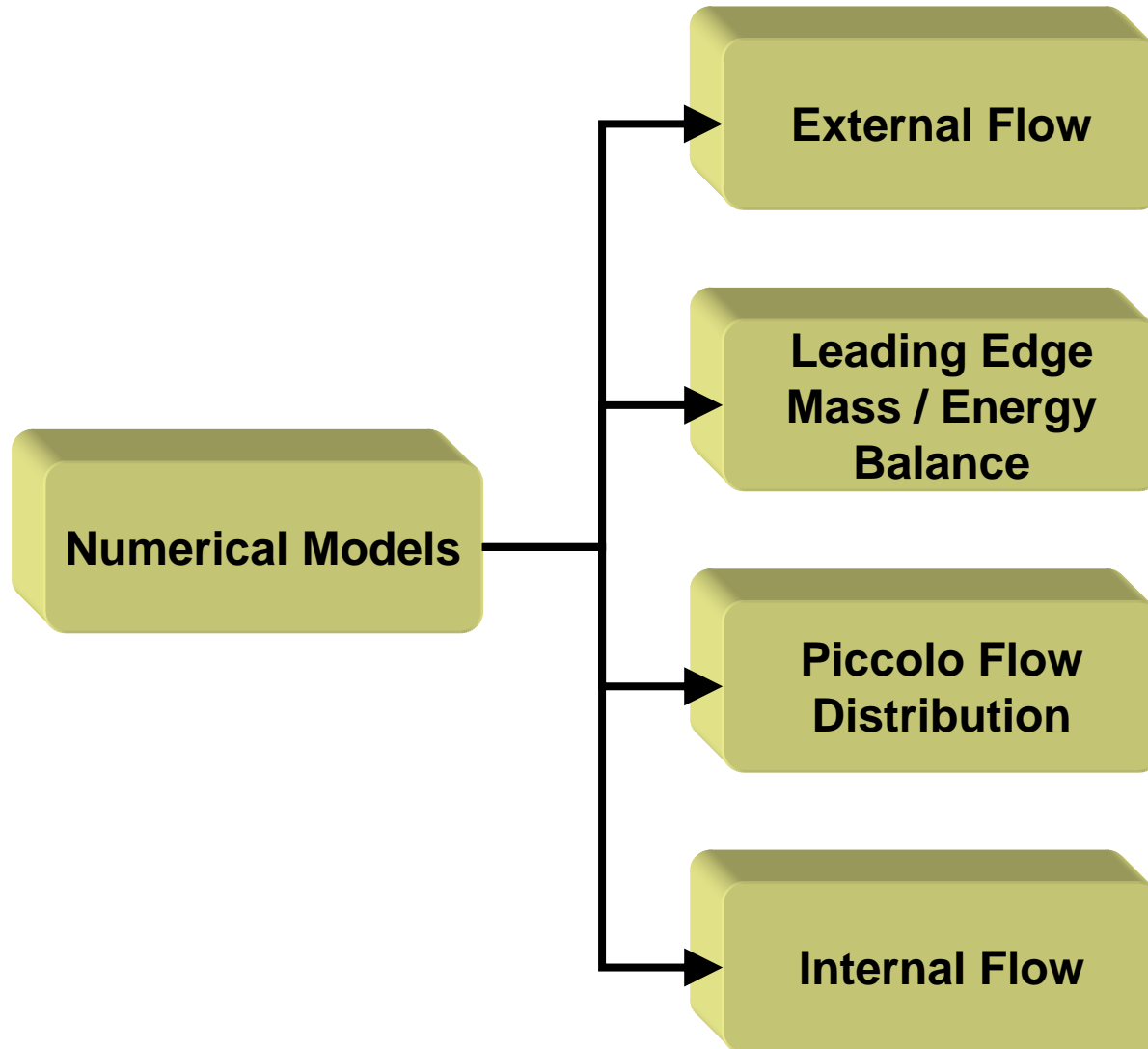

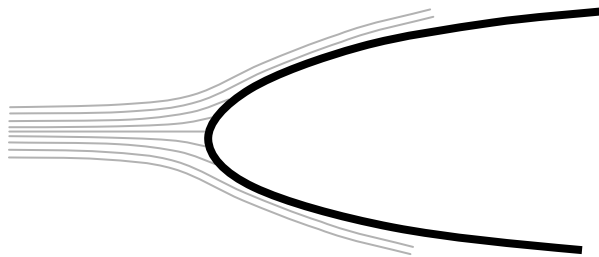
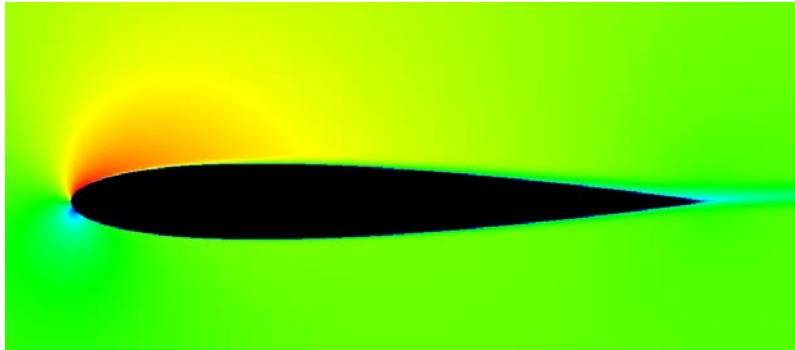

- Cp Distribution
- External HTC
- Wall Shear
- Droplet Trajectory
- Water Catch Efficiency
- Droplet u and v components

Applied Tools:

Full 3D Navier-Stokes CFD

- ⊕ ANSYS FLUENT
- ⊕ Metacomputech CFD++
(Eulerian particles trajectory)

2D Panel Method

- ⊕ 2D Lagrangean Droplet Trajectory
- ⊕ Two Boundary Layer Tools for HTC

- **Optional External HTC Tool**
- **Integral boundary layer method**
- **Takes into account the presence of EVAPORATION and skin TEMPERATURE GRADIENT. May be more adequate than traditional single phase flow solutions**
- **Requires**
 - ⇒ **Pressure distribution**
 - ⇒ **Wall shear distribution**
 - ⇒ **Skin temperature distribution**
 - ⇒ **Water evaporation rate distribution**
- **Iterative solution**

- Implements the Messinger model, performing a 2D mass and energy balance on the impinged water film + leading edge skin
- Required BC's:
 - ⤷ Water catch efficiency distribution
 - ⤷ Local Internal HTC
 - ⤷ External flow properties
- Calculates:
 - ⤷ Ice accretion (ice shape)
 - ⤷ Intermediate states / residual ice (with internal hot-air heating)
 - ⤷ Ice clear shapes (with internal hot-air heating)

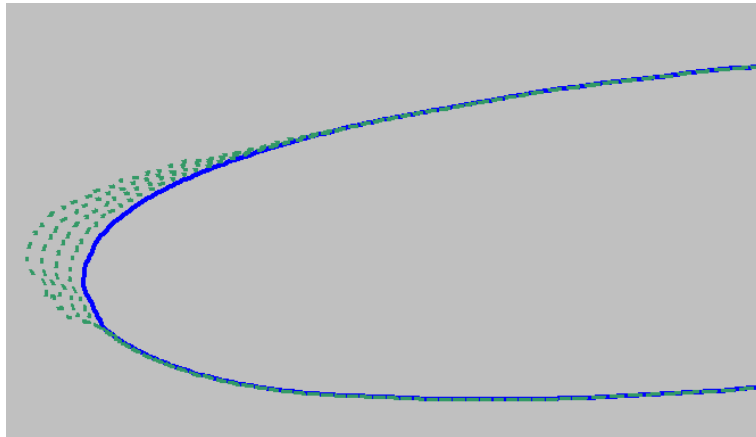

No heating / Ice Shape

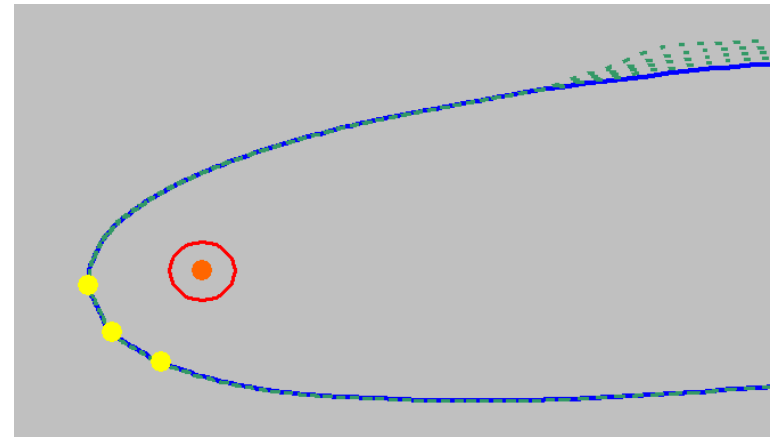

Heating / Residual Ice

→ Consists of a Piccolo Distributed Loss Model

→ Requires:

- Piccolo external surf. HTC
- Chamber temperature

→ Calculates:

- Mass flow distribution
- Pressure distribution
- Temperature distribution

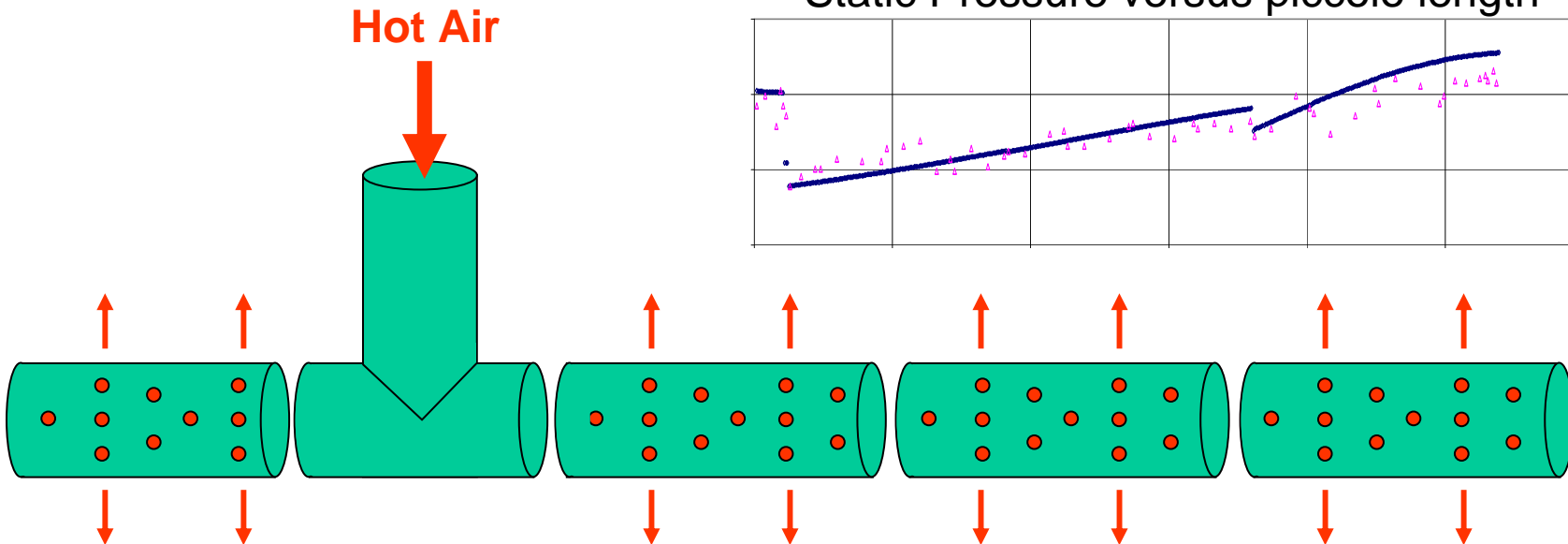

Flow per hole versus piccolo length

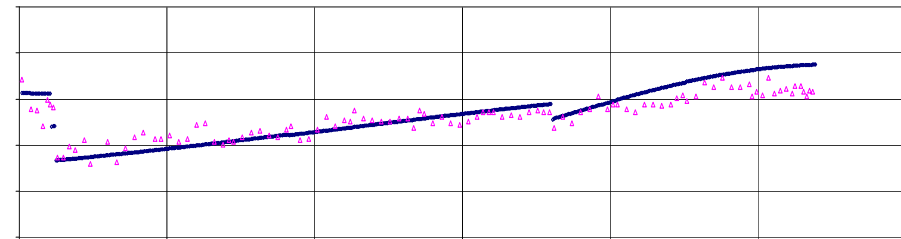

0.01 ppm

Static Pressure versus piccolo length

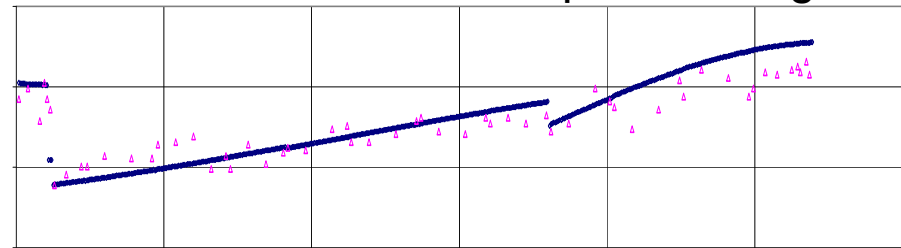

1 psig

- ➔ **EMPIRICAL CORRELATIONS** for “Local Heat Transfer Coefficient to an Impinging Circular Air Jet” (Goldstein et al)
- ➔ Local HTC in function of Reynolds Number at piccolo’s holes and geometric parameters

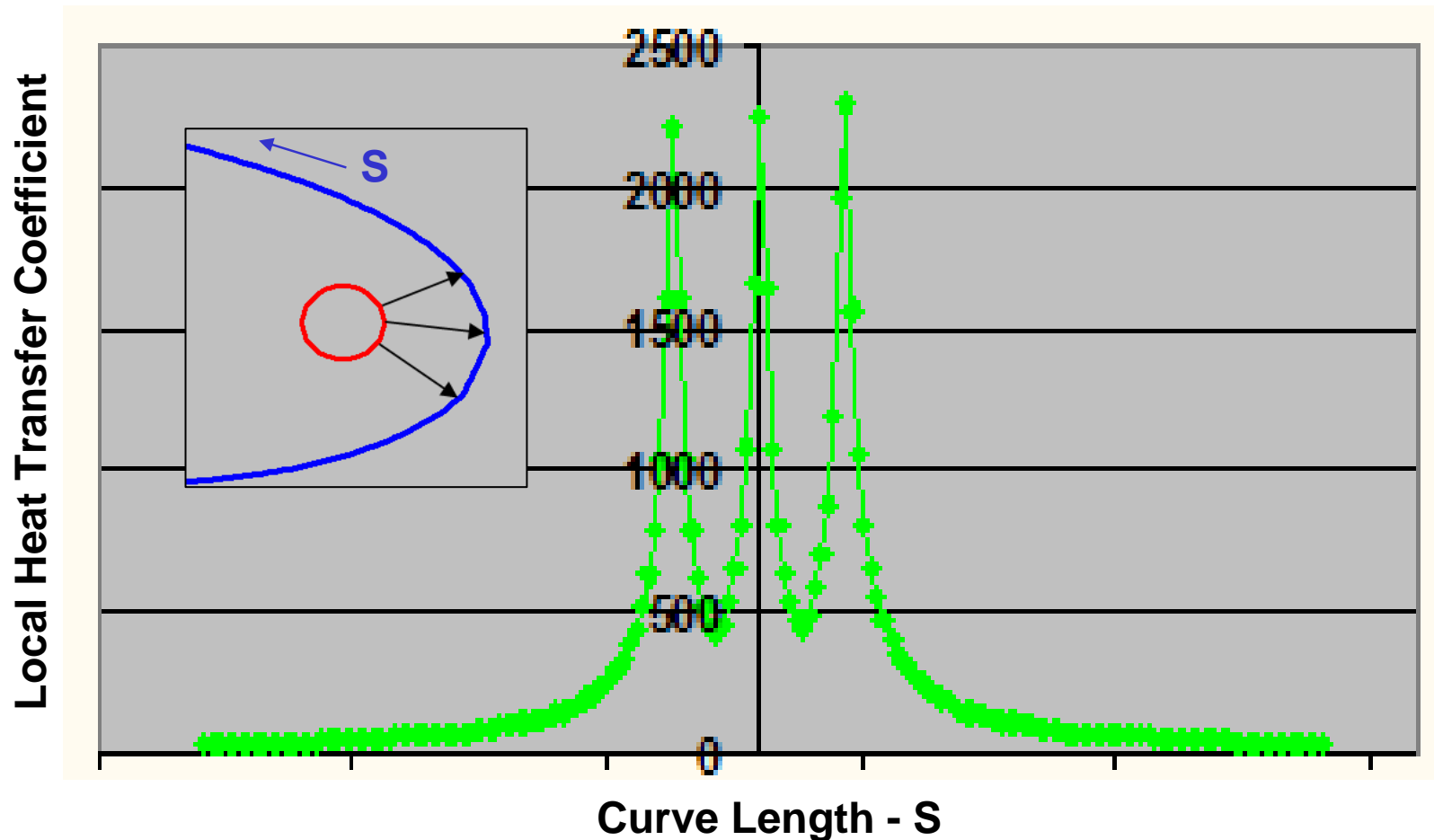

CFD

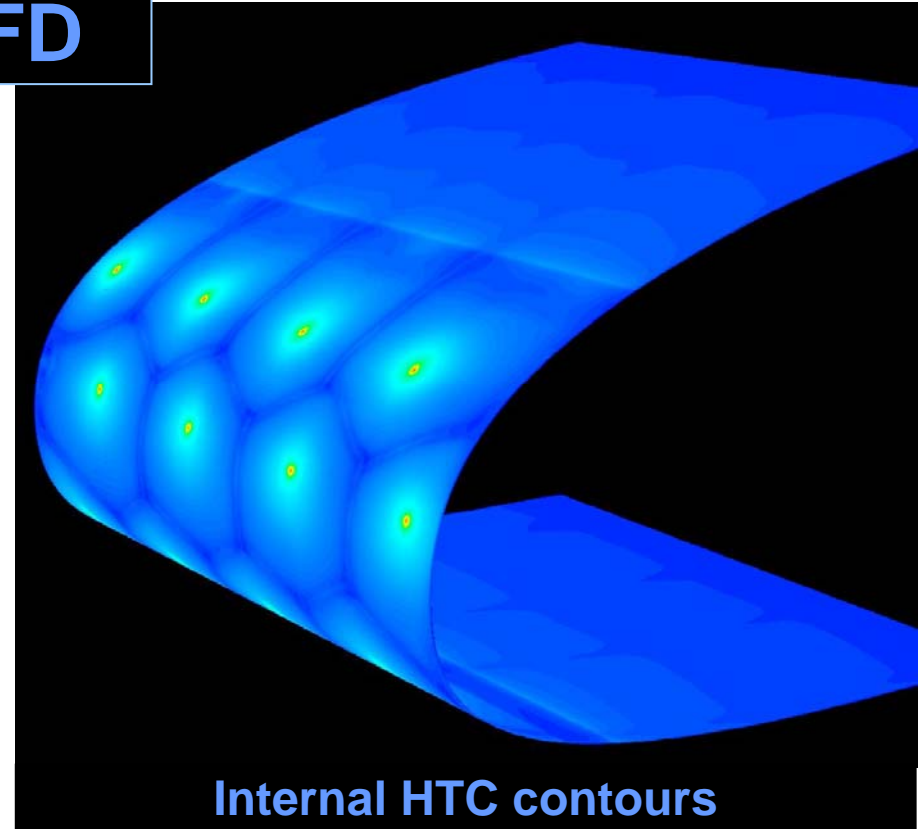
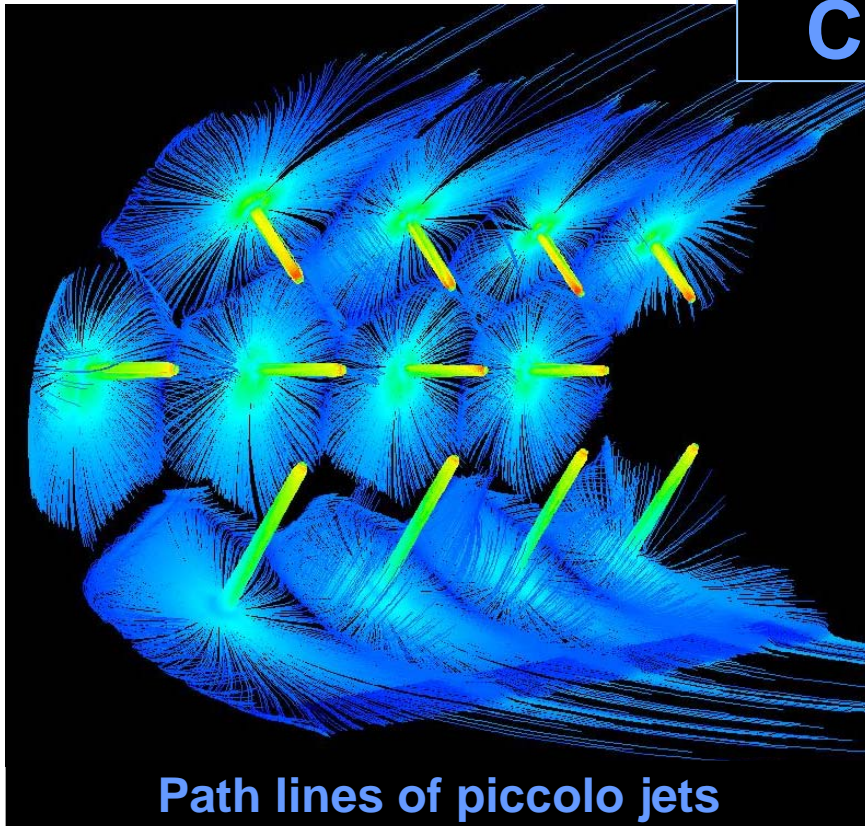

→ **Boundary Condition:** Requires the wall temperature distribution, resulting on an iterative solution between CFD and *Aeroicing* (and *PoliBL*)

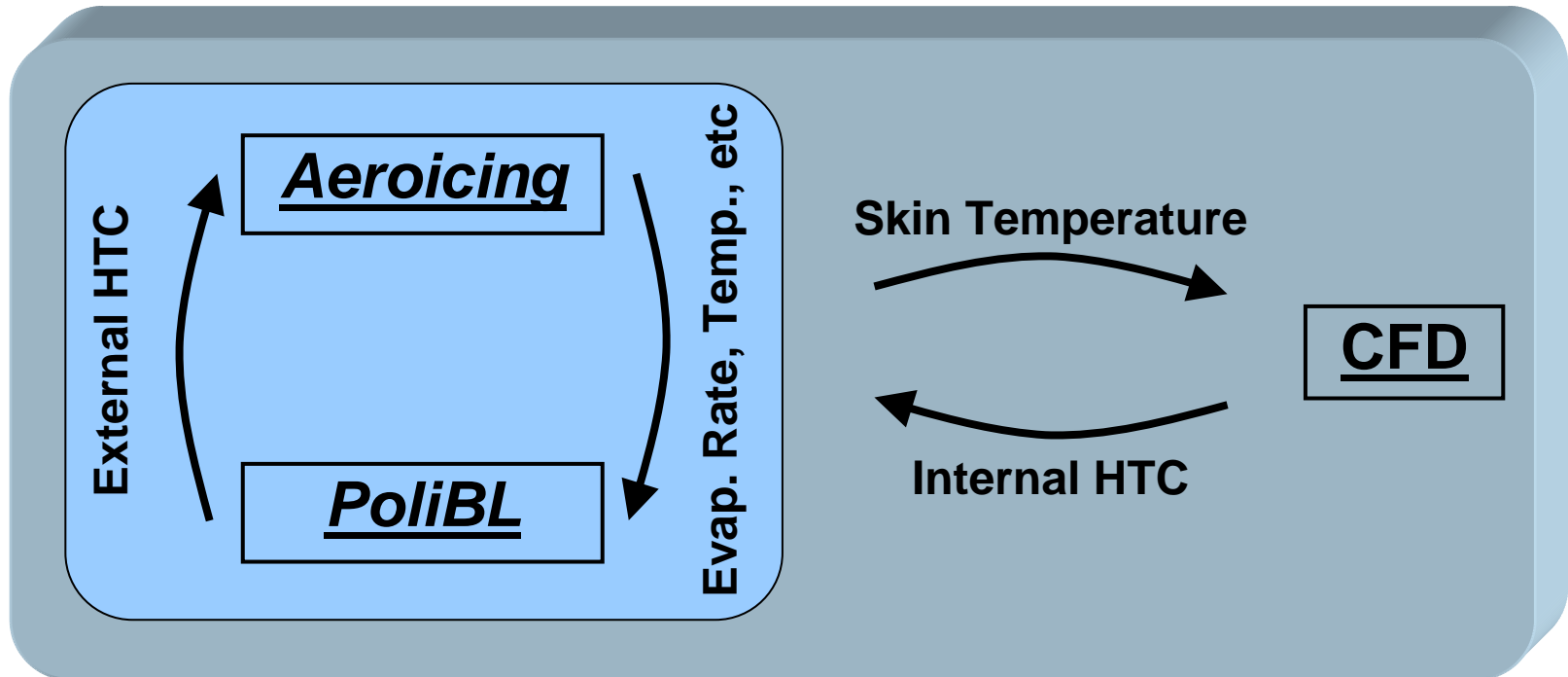
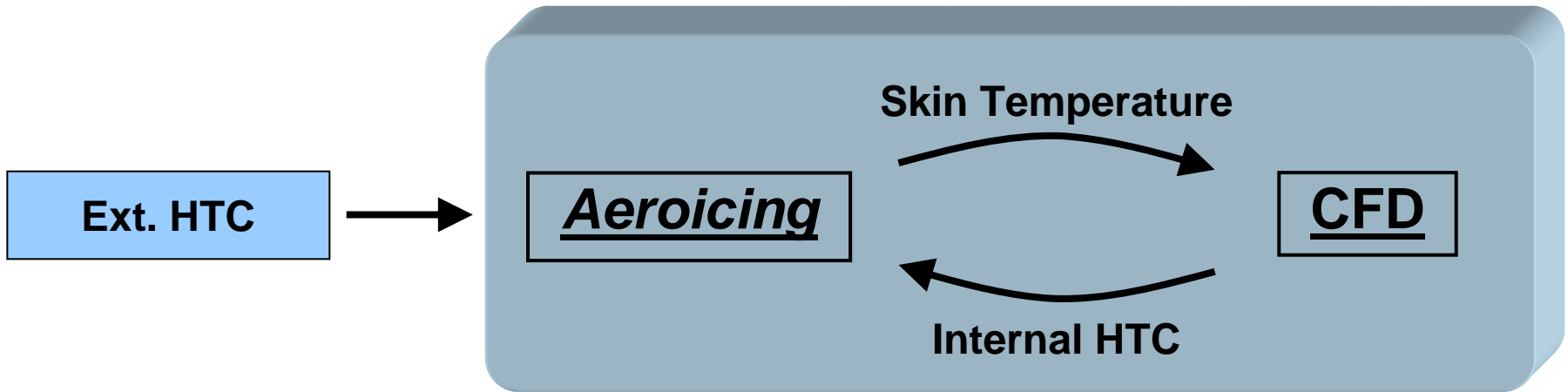

- Stand alone preliminary integration tool
- Requires as Input only:
 - ⇒ Water catch efficiency distribution
 - ⇒ External Cp distribution
- Mass and Energy balance on the leading edge
- External and Internal HTC are based on empirical correlations
- Considers only ICE FREE surfaces
- Provides:
 - ⇒ Skin temperature
 - ⇒ Evaporation rate
 - ⇒ Runback water rate / extent
- May be used for preliminary piccolo design optimization

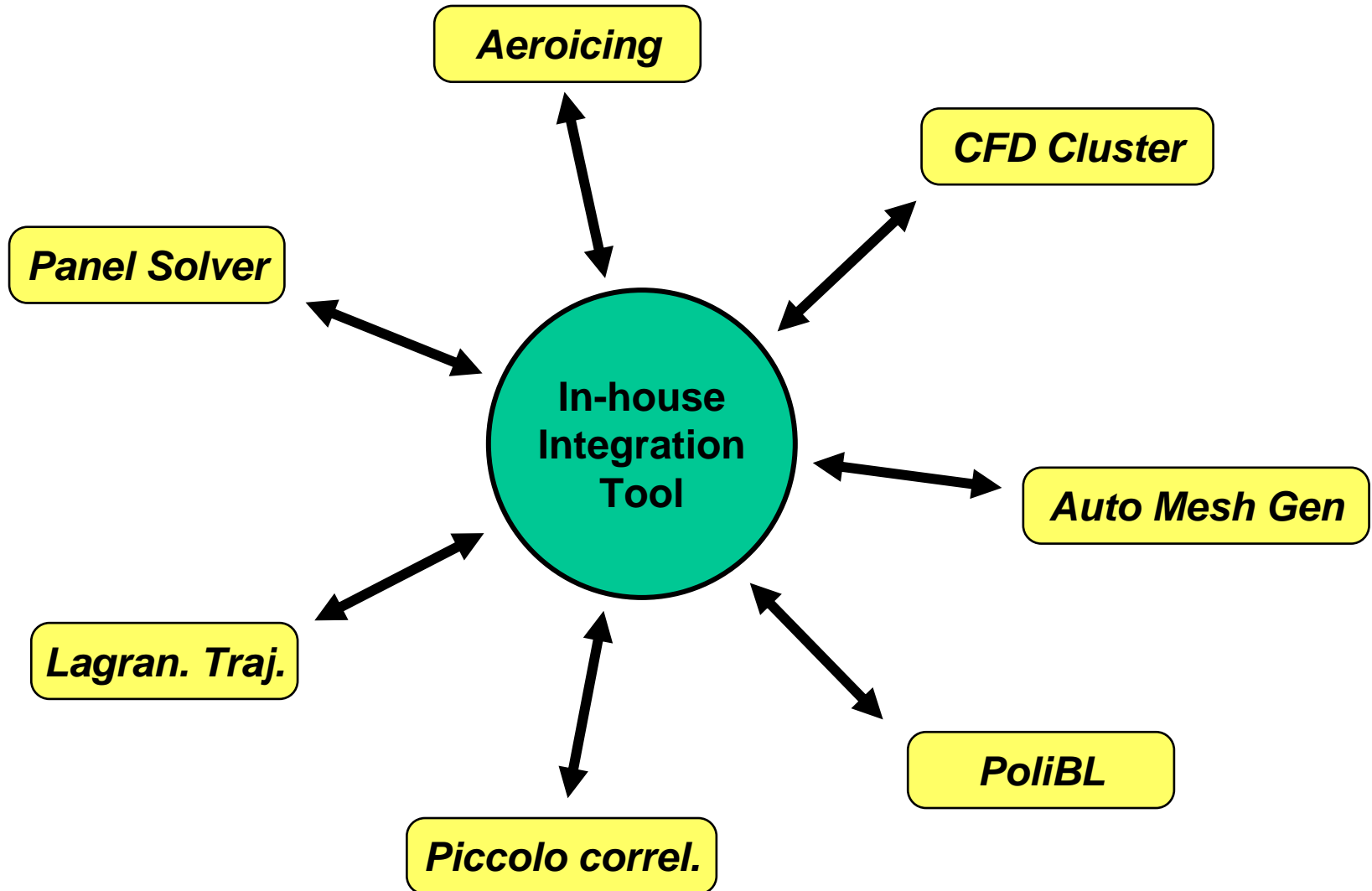

PRELIMINARY SYSTEM DESIGN

- **Flight and Atmospheric Conditions**
- **2D Section for the External Analysis**
- **2D versus Target 3D External Flow**
- **Preliminary Piccolo Design Optimization**
- **Selection of Critical Cases**

ICING WIND TUNNEL TESTS

- **Leading Edge Model**
- **Scaling**

RESULTS AND VALIDATION

- **CFD for Internal HTC**
- **Correlation for Internal HTC**

CONCLUSION

Set of points to represent CM Icing Envelope of the Appendix C to Part 25

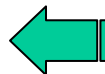
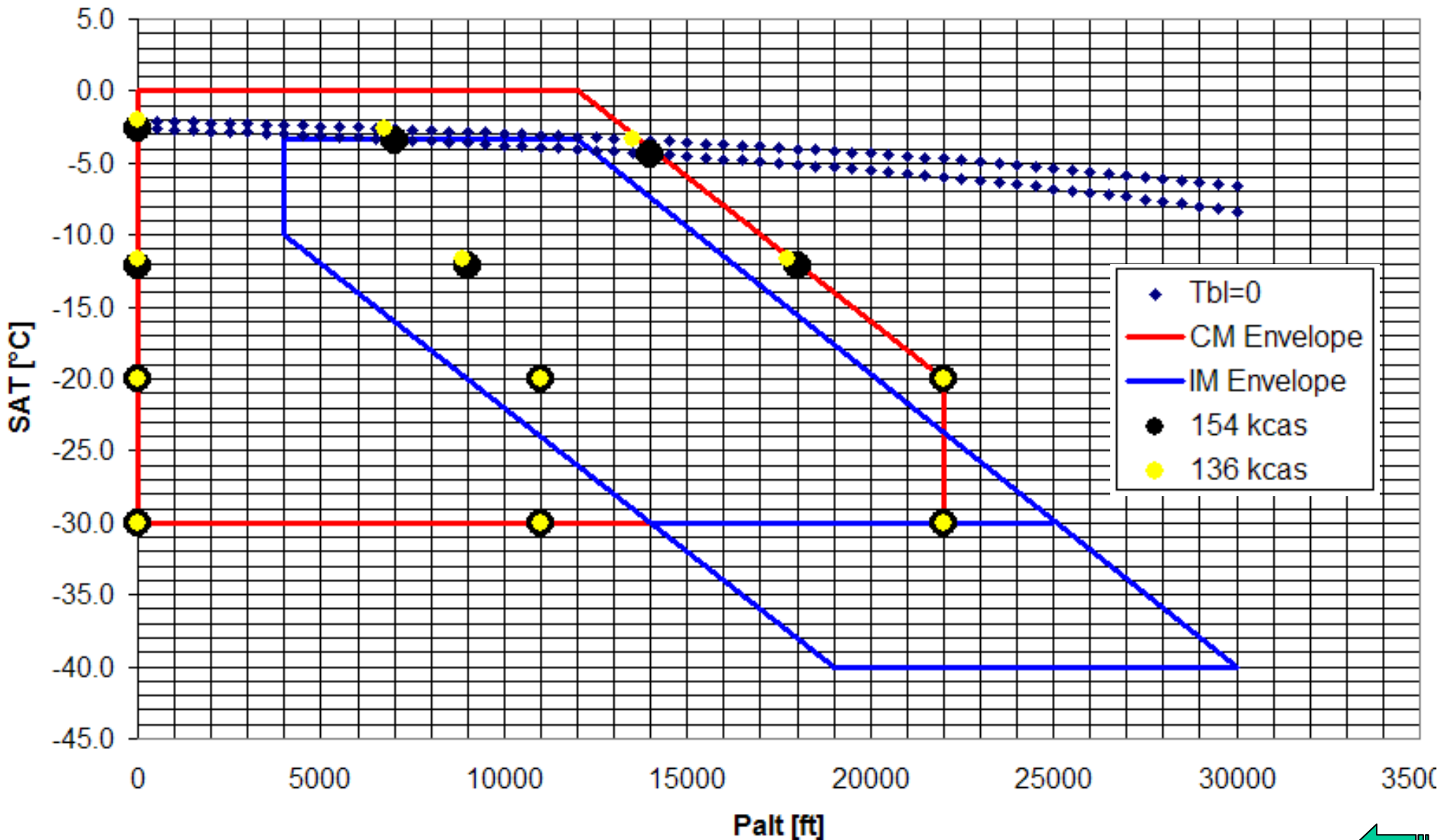

- The water collection coefficient distribution is calculated for the selected flight and atmospheric conditions
- The critical section is selected

- The 3D geometry is represented by a 2D cut that reproduces the critical section's external flow

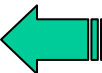
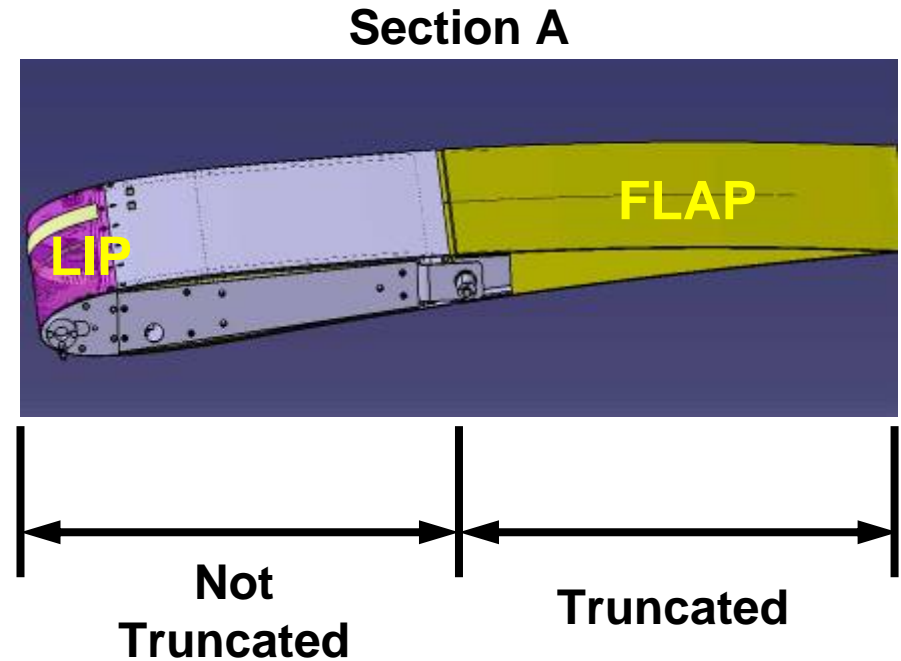
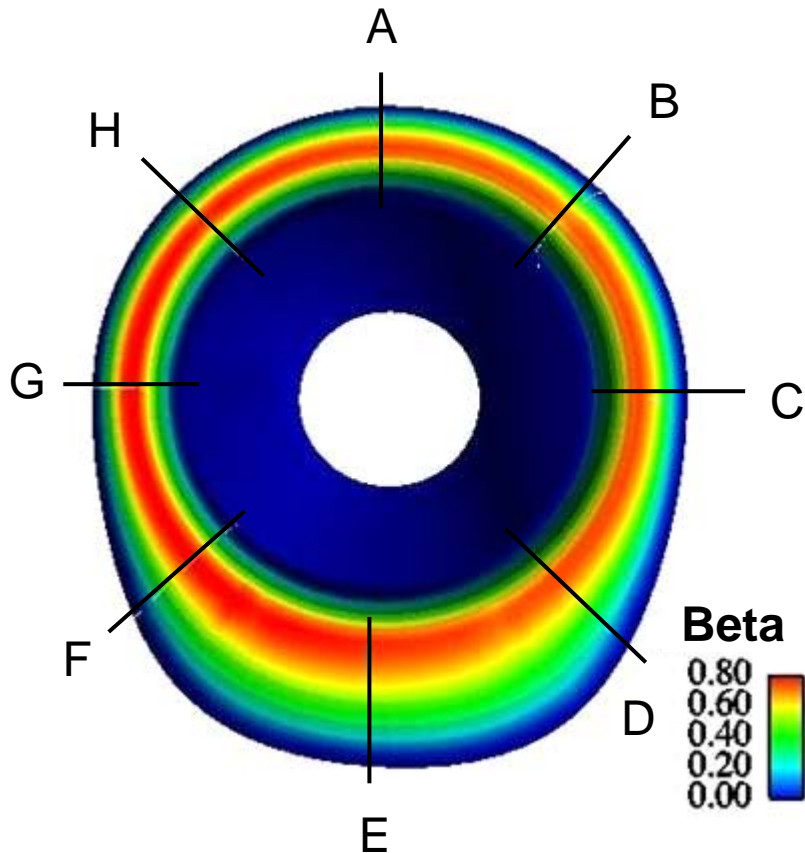

- 1) To solve the external flow including the engine effects using a full 3D Navier-Stokes CFD code
- 2) To solve the 2D flow varying the AoA until satisfactorily matching the C_p at the LE, using potential flow codes

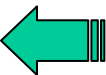
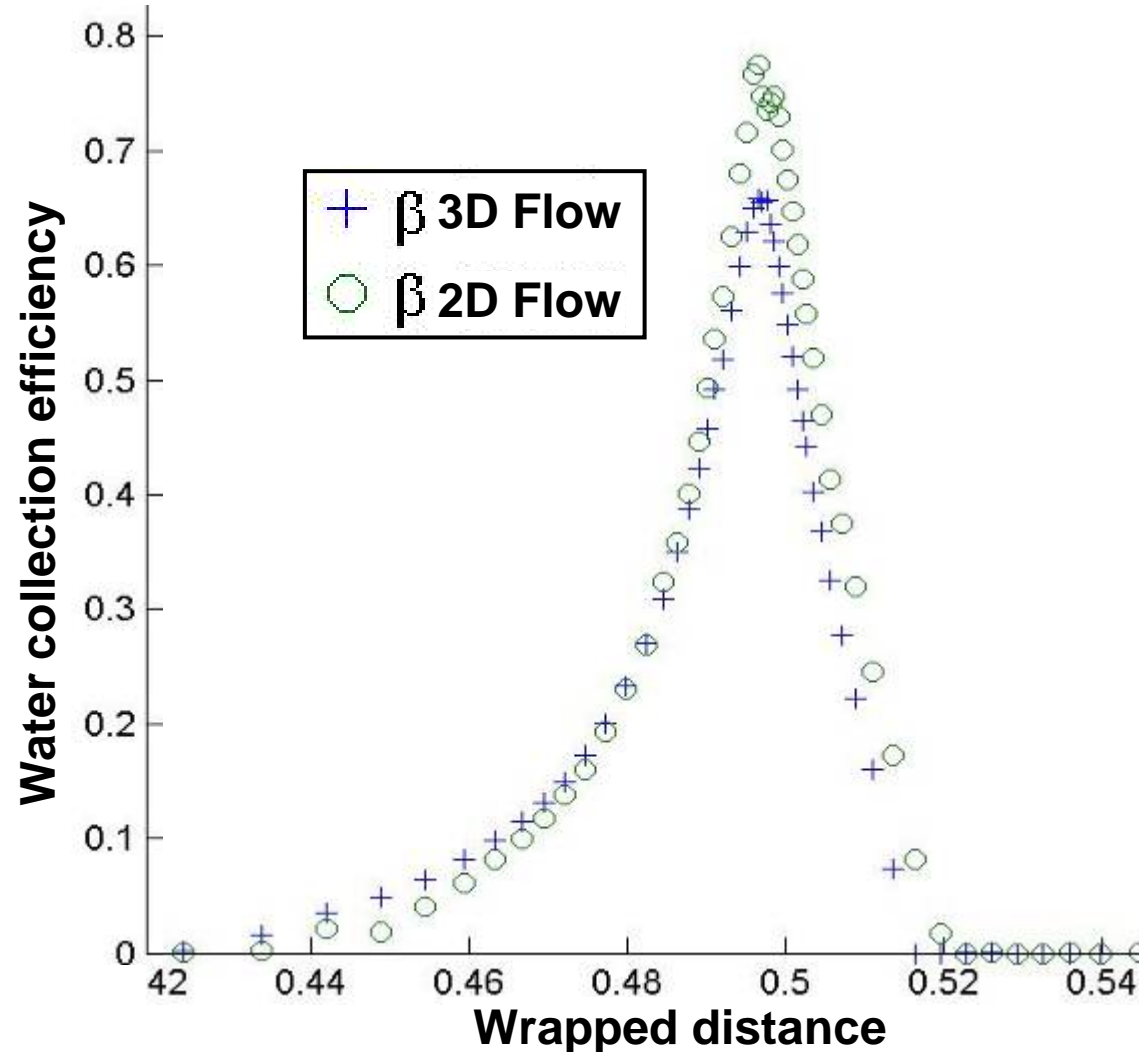

- Initial Piccolo configuration based on past experience
- The simplified stand alone simulation tools are used (*Freepic + Freeice*)
- Geometric parameters to be optimized :
 - X** – picc. center
 - y** – picc. center
 - θ_1 – jet angle
 - θ_2 – jet angle
 - θ_3 – jet angle
 - D** – picc. diameter
- Select the best configuration by runback water extent and temperature criteria

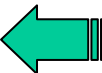
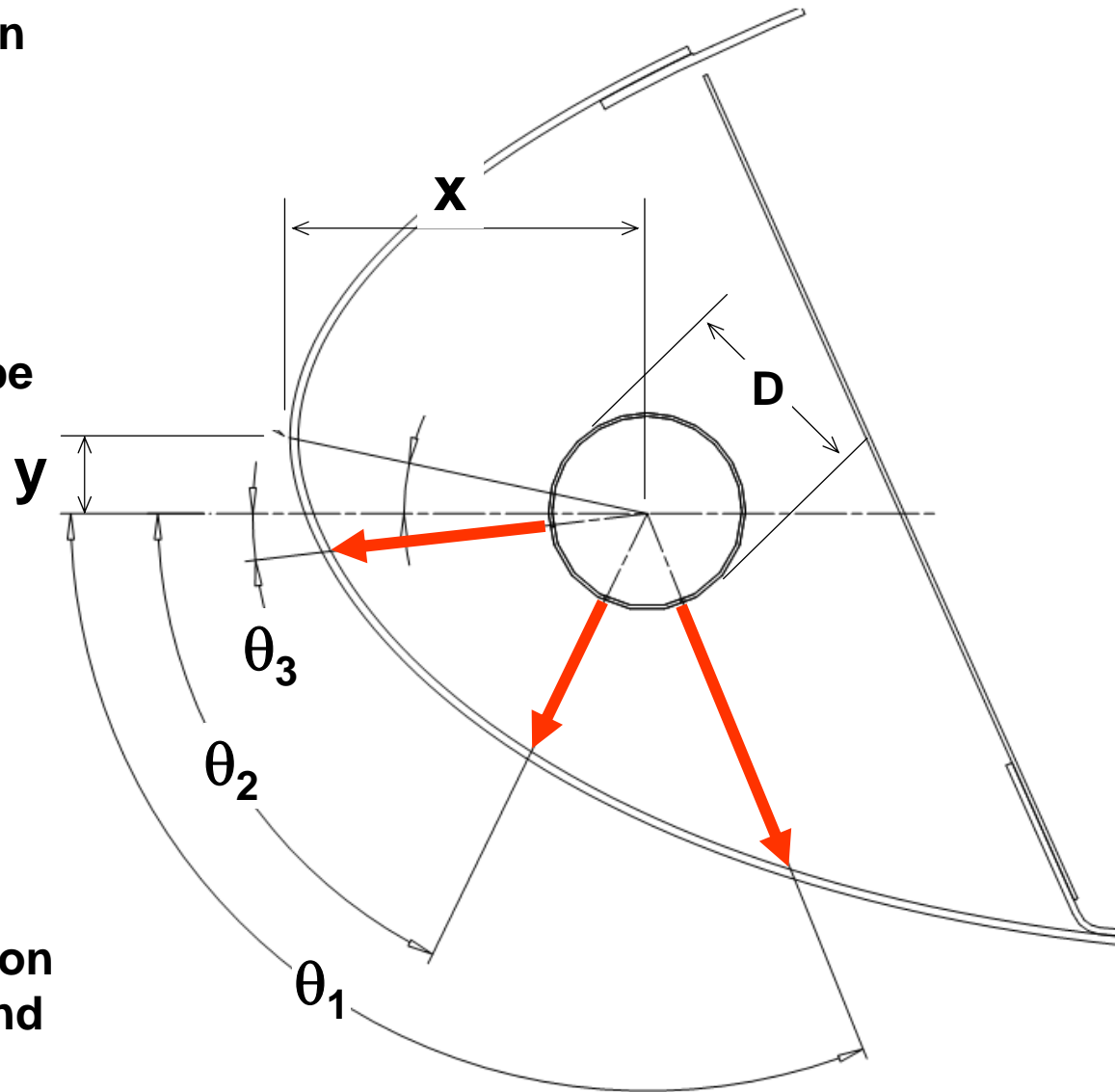

- For some optimized piccolo tubes configurations, the set of points representing CM Icing Envelope is
- The cases with the longest runback water extent are selected to be tested in icing wind tunnel
- Additional cases are also selected, for robustness of the validation process

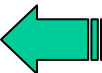
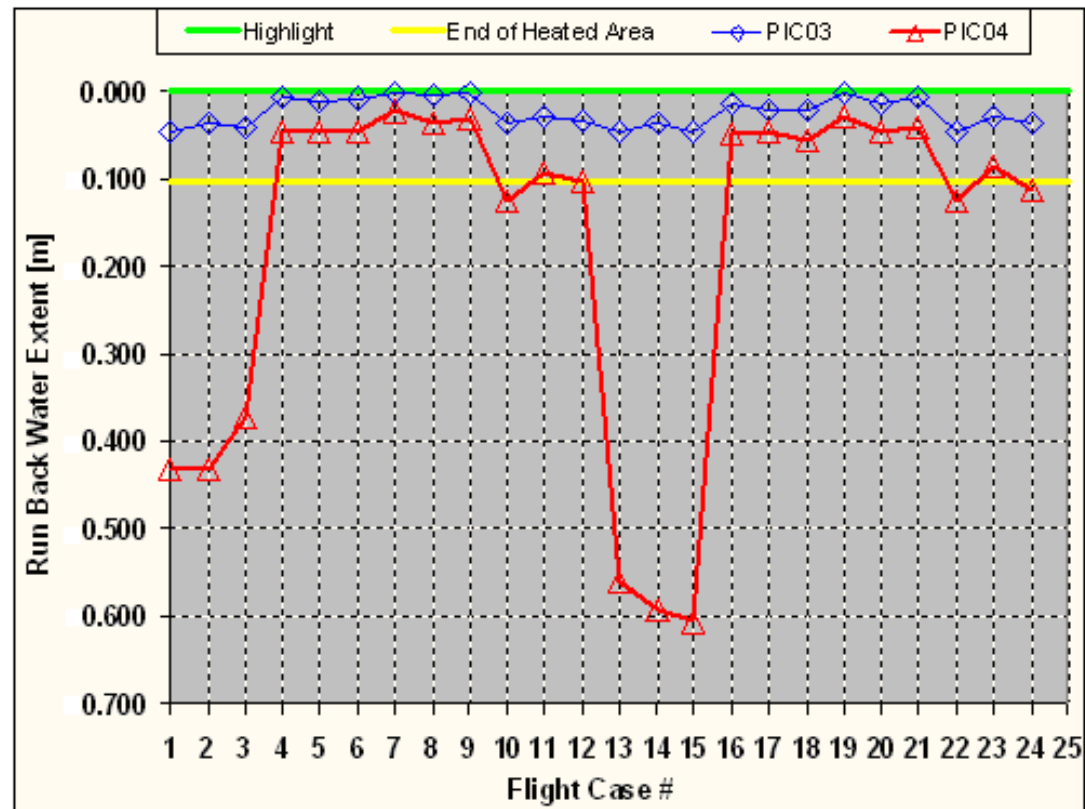

BFGOODRICH ICING WIND TUNNEL

Heat Flux Meters
Thermocouples
Pressure Transducers

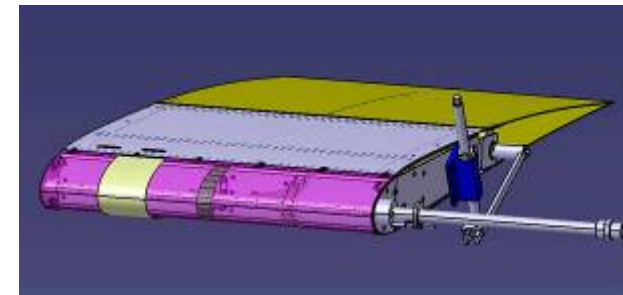
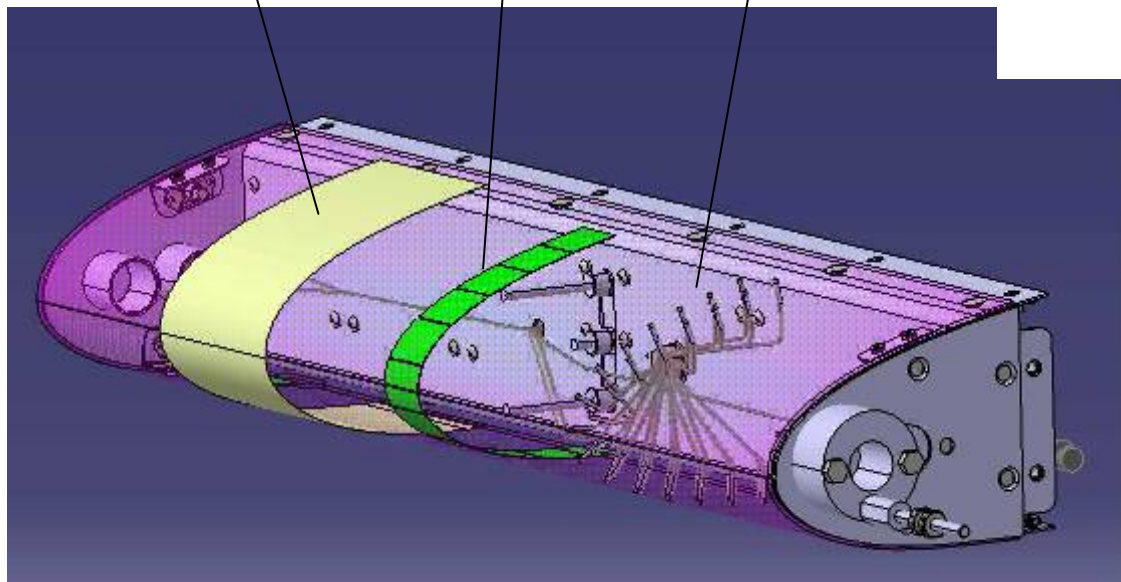
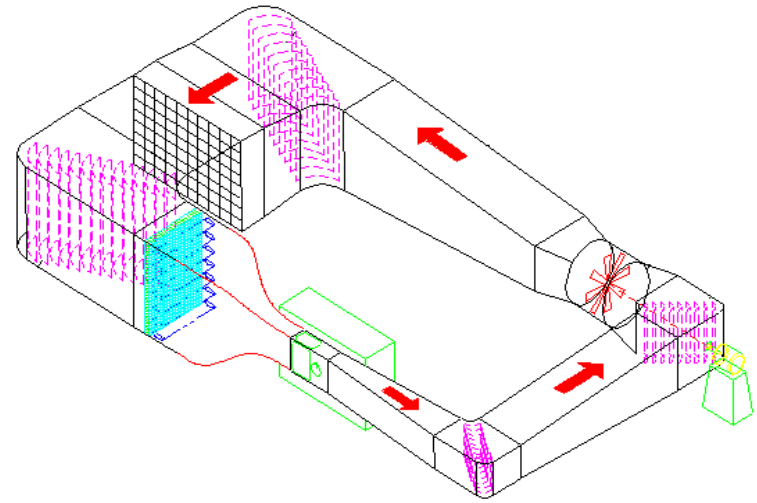

Leading Edge with Instrumentation

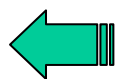

→ Tunnel parameters are varied in order to reproduce flight conditions:

- ⇒ Velocity
- ⇒ Static Temperature
- ⇒ Liquid Water Content
- ⇒ Droplet Medium Volumetric Diameter

→ Flight and Tunnel parameters matched by scaling:

- ⇒ Modified Inertia Parameters → Catch Efficiency at Stagnation
- ⇒ Total Air Temperature
- ⇒ Water Impingement Rate

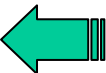

- External Flow Field: Potential Flow
- Droplets Trajectories: Lagrangean
- External HTC: *PoliBL*

- Internal HTC: 3D Navier-Stokes CFD
- Skin Temperature: Aeroicing

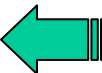
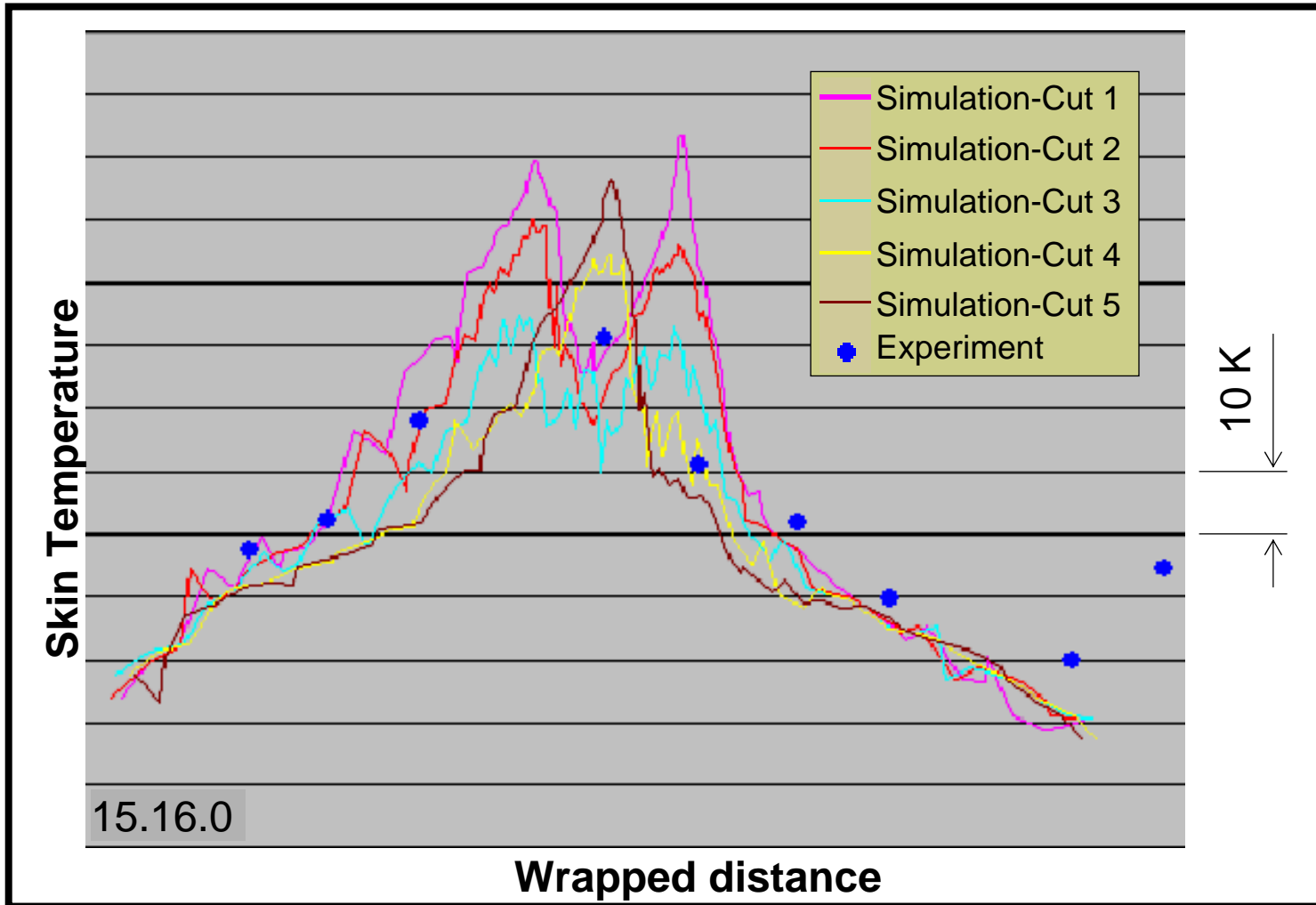

- External Flow Field: Potential Flow
- Droplets Trajectories: Lagrangean
- External HTC: *PoliBL*

- Internal HTC: Piccolo Correlation
- Skin Temperature: Aeroicing

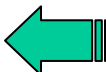
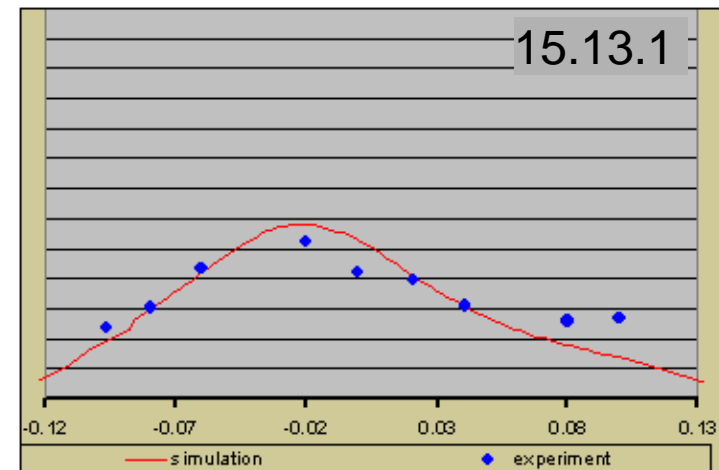
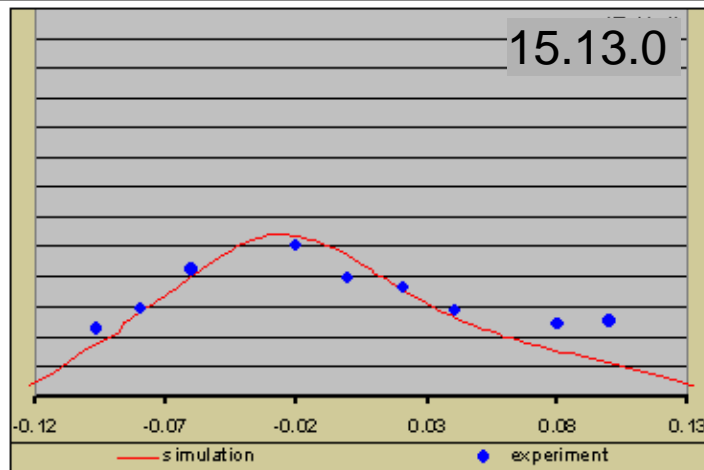
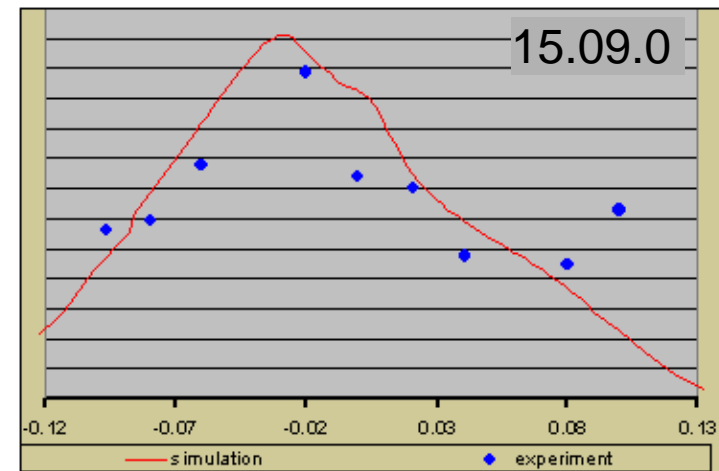
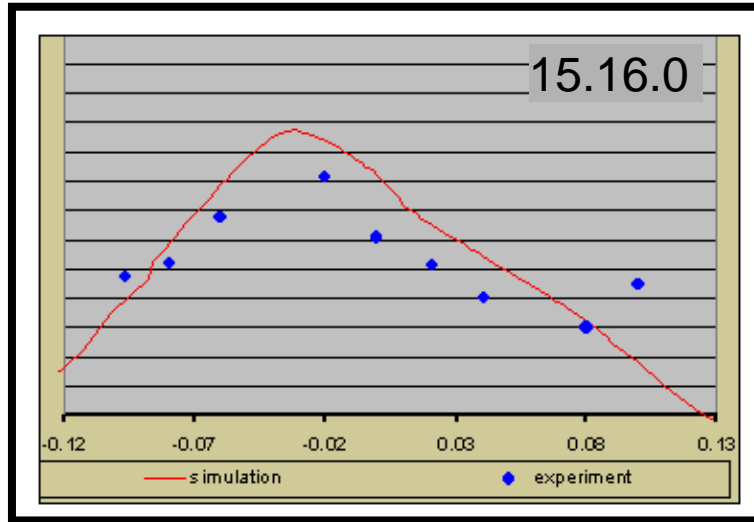

- **Combination of numerical tools can provide good agreement with the experimental results**
- **The use of correlations, combined with CFD and experiments has shown the adequate balance combining efficiency and accuracy**

THANK YOU!