

# The Effects of Ice Accretion on Airplane Handling Qualities

(Certification for Flight in Icing)

- Ice Contaminated Tailplane Stalls
- Roll Upset

Joe A. Brownlee, FAA Flight Test Pilot

25 September 2007



Federal Aviation  
Administration



# Program

## History

- Accidents
  - ICTS
  - Roll Upset
- **Aerodynamics**
- **Analysis**
- **Flight Test Maneuvers**
- **Evaluations**
- **Flight Test Safety**

# Accident Scenarios

- **Attributable to Ice Contaminated Tailplane Stall**
  - Approach in icing conditions.
  - Ice protection systems used and not used.
  - Control difficulty experienced or impact occurred usually after wing flap extension and glide slope capture.
- **Attributable to Roll Upset**
  - Cruise in icing conditions, including Supercooled Large Droplets.
  - Change in wing AoA with wing flap operation and/or airspeed reduction and/or increased load factor.

# Aerodynamic Considerations

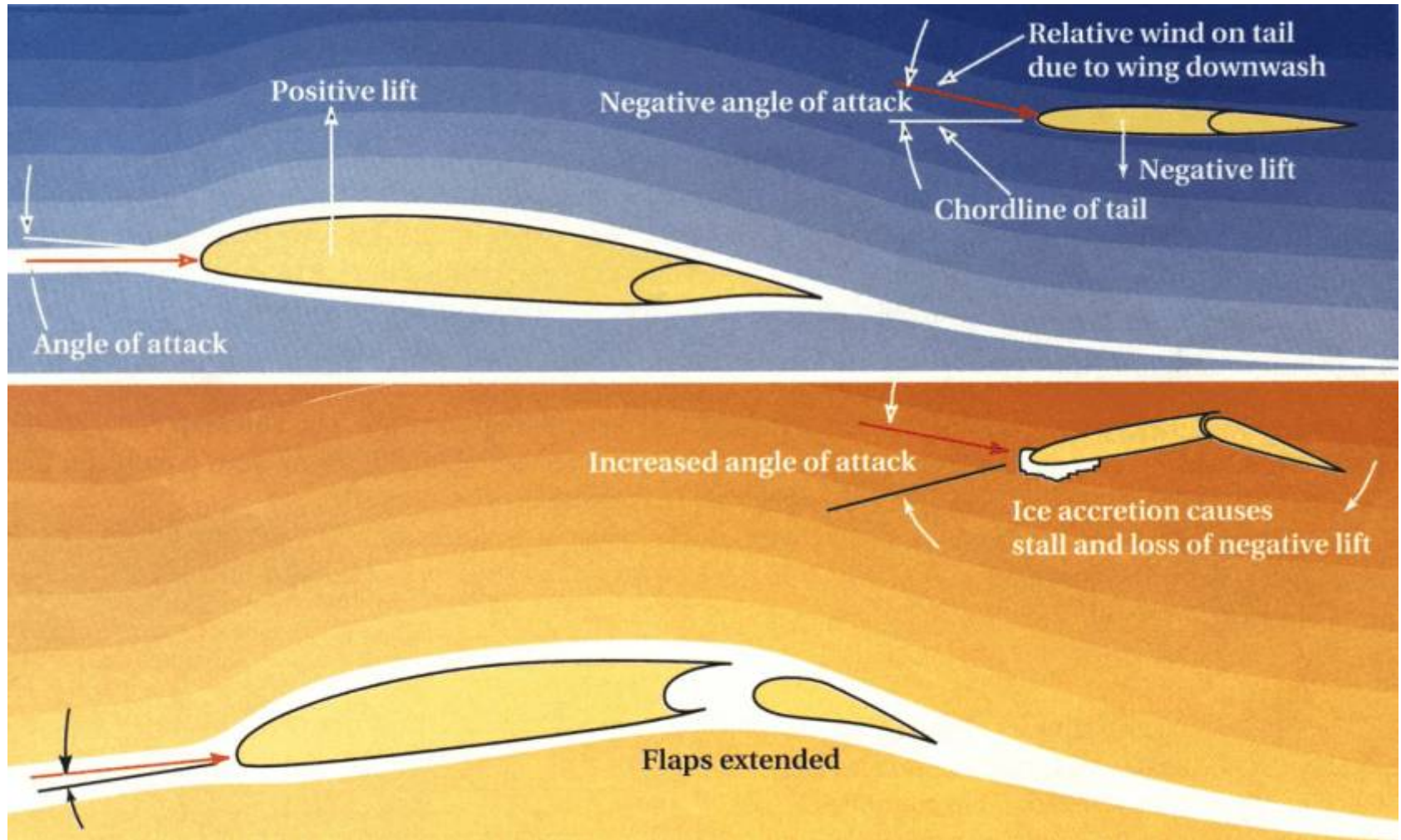

# Maneuver Considerations

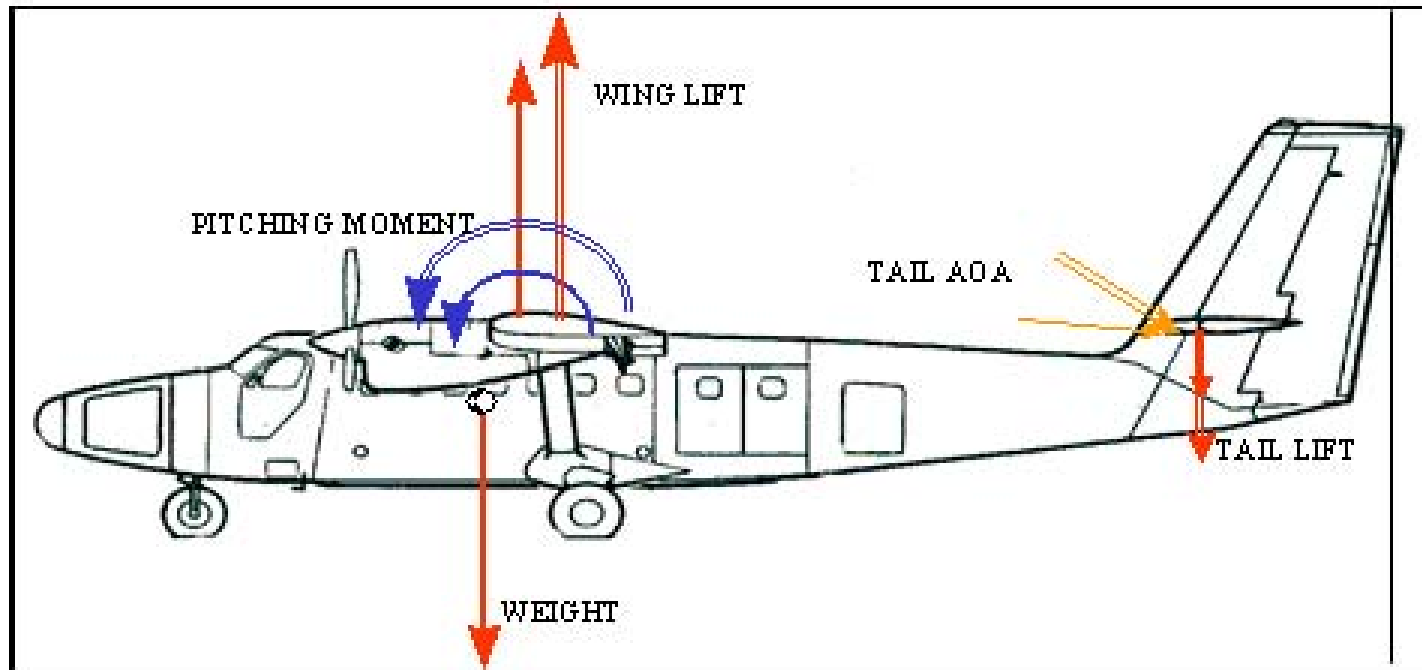

# ICTS Defined

Ice Contaminated Tailplane Stall can be characterized either by completely stalled airflow over the horizontal stabilizer; or by an elevator hinge moment reversal due to separated flow on the lower surface of the horizontal stabilizer; or both, caused by ice accretions on the tailplane.

# Airplane Design Affecting ICTS

(International Tailplane Icing Workshop , November 1991)

- **Manual flight control systems which rely on control surface aerodynamic balance to reduce longitudinal control forces (reversible control systems).**
- **High efficiency wing flaps producing relatively high downwash resulting in high angle of attack on the horizontal tailplane.**
- **Non-trimmable (fixed) stabilizers with efficient airfoils.**
- **Stabilizer area small with respect to the wing (low tail volume coefficient).**
- **Cruciform and T-Tails are included these design considerations.**
- **(Later NASA Tests revealed Propeller Induced Flow as also increasing tailplane angle of attack.)**

# Historical Problem

## Cessna 172N (1980)

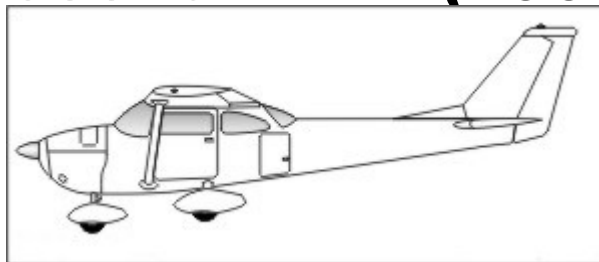

## PROCEDURES for

## INADVERTENT ICING ENCOUNTER

**“Leave wing flaps retracted. With a severe ice build-up on the horizontal tail, the change in wing wake airflow direction caused by wing flap extension could result in a loss of elevator effectiveness.”**

# FAA Funded ICTS Analysis of Operational Airplanes – 1994

by Peter Helsten

## Considerations:

- Cruise, Approach and Landing Configurations
- Tailplane leading edge uncontaminated and “standard roughness” over first 0.8% of chord – sandpaper ice
- Tailplane Stall Margin defined as the difference in lift coefficients between the operating  $C_l$  in a specific configuration and airspeed, and the maximum  $C_l$  for that configuration.

# Hellsten Study ICTS Susceptibility Factors

- **Efficiency of Wing Flap System**
  - Downwash flow changes
  - AoA changes due to wing flap deployment
- **AoA of tailplane**
  - Impact of downwash
  - Impact of changes in wing AoA
  - Effect of fixed incidence or variable incidence tailplane (trim)
- **Relative Tailplane Size**
  - Tail operating lift versus required lift for phase of flight
  - Tail volume coefficient as a measure of relative tailplane size
- **Tailplane Airfoil Section**
  - Susceptibility to lift degradation with ice accretion

# Hellsten Study ICTS Analysis Maneuver

## Zero G Pushover at $1.3 V_s$

(1.3 times the Stall Speed in the specified wing flap and landing gear configuration.)

# Helsten Study Results

- Airplanes with low or negative tailplane stall margins had ICTS accident or incident histories. Susceptibility to ICTS was predicted.
- Airplanes with trimable horizontal stabilizers (ability to change tailplane incidence) had, at that time, no records of ICTS related accident or incident histories.

# Pitch Rate about Airplane Center of Gravity and Tailplane Angle of Attack

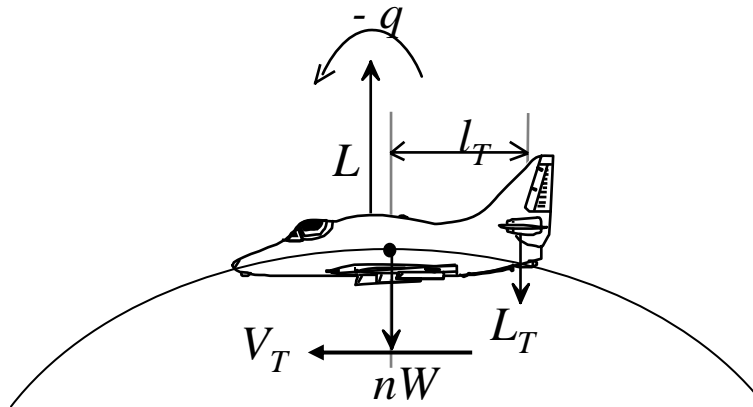

$q$  = pitch rate about CG  
 $l_T$  = distance from CG to tailplane aerodynamic center  
 $V_T$  = linear (tangential) velocity

Tailplane vector diagram:

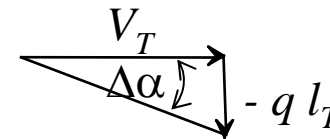

$$\therefore \alpha = \frac{-q l_T}{V_T}$$

**Therefore a pushover increases the tail plane negative AoA proportional to the pitch rate.**

$$CF = \frac{W}{g} q^2 R = \frac{WV_T^2}{gR^2} R = \frac{W}{g} V_T q$$

During the pushover maneuver, the test pilot targets an applied normal acceleration  $\equiv n_a = n - 1$ , where  $n \equiv$  the existing normal acceleration; therefore in level flight,  $n = 1$  and there is no pitch rate.

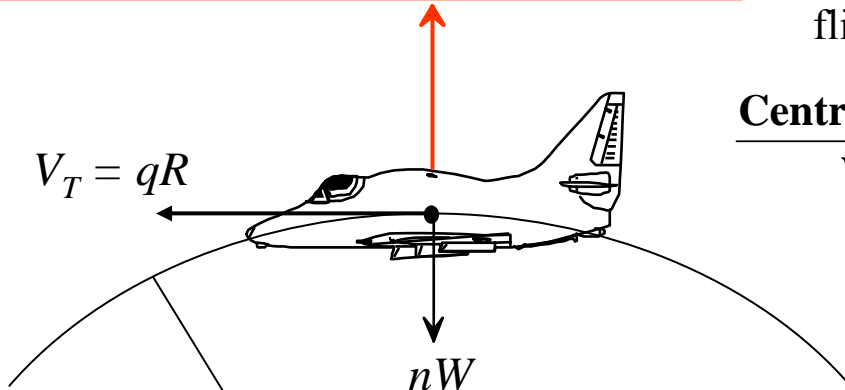

$$\frac{\text{Centrifugal Force}}{\text{Weight}} = n_a = \frac{WV_T q}{Wg} = \frac{V_T q}{g} = n - 1$$

Rearranging:

$$q = \left( \frac{n - 1}{V_T} \right) g$$

Therefore; in generating a pitch rate, the test pilot controls centrifugal force.

For Zero G,  $n = 0$ ;  $\therefore q = -\frac{g}{V_T}$

**(At a true airspeed of 100 knots, Zero G produces a pitch rate of 10.9°/second.)**

$$q = \frac{V_T}{R}$$

$q$  = pitch rate in radians per second

$R$  = radius

$V_T$  = linear velocity

$CF$  = centrifical force

# Basic ICTS Evaluation

(paraphrased)

Conduct a pushover maneuver down to a Zero G load factor with the critical ice accretion on the airplane. (If the airplane lacks enough elevator power to achieve a Zero G load factor, the maneuver may be ended at the lowest load factor obtainable.)

# Basic Criteria of Controllability and Maneuverability

1. A longitudinal control push force is required throughout a pushover maneuver down to a Zero G load factor, or the lowest load factor obtainable if limited by elevator power or other design characteristic of the flight control system.
2. It must also be possible to promptly recover from the maneuver without exceeding a pull control force of 50 pounds; and

# Basic Criteria of Controllability and Maneuverability - continued

3. any changes in force that the pilot must apply to the pitch control to maintain speed with increasing sideslip angle must be steadily increasing with no force reversals, unless the change in control force is gradual and easily controllable by the pilot without using exceptional piloting skill, alertness, or strength.

# Ice Accretion versus Evaluation Criteria

**For flight in icing conditions before an ice protection system has been activated and is performing its intended function, the following requirements apply:**

- If activating an ice protection system depends on the aircrew observing a specified ice accretion on a reference surface (not just the first indication of icing), the pushover requirements to Zero G apply with the ice accretion defined in appendix C.

# Ice Accretions and Configurations

**Basically, the most critical ice accretion.**

**Holding Ice, as defined in new Appendix C;  
and, for airplanes with unpowered  
(reversible) elevators, Sandpaper Ice.**

**Medium to light weight, the most critical center-of-gravity position, symmetric fuel loading, and the highest lift landing configuration.**

# Evaluation Based on Type of Ice Detection System

Ice detecting systems that alert the aircrew to activate ice protection at the onset of icing conditions, or automatic activation of ice protection systems, require evaluation criteria less stringent.

This reflects the expectation that the airplane would fly only briefly in icing conditions before ice protection system activation and operation.

# Evaluation Based on Type of Ice Detection System - continued

Instead of the criteria of a Zero G pushover and side slip, the requirement is an evaluation that there is no longitudinal control force reversal during a pushover maneuver down to a 0.5 G load factor and that the airplane is controllable in a pull-up maneuver up to 1.5 G load factor.

# Ice Accretion for 1/2 G Pushover

The ice accretion formed on the unprotected and normally protected surfaces before activation and effective operation of the ice protection system in continuous maximum atmospheric icing conditions defined in 14 CFR Part 25 Appendix C.

# The Flight Test Maneuver

With the airplane at most critical center of gravity; in trim, or as nearly as possible in trim, at the most critical of the trim speeds specified below; pull up to a suitable pitch attitude, then push over in a continuous maneuver (without changing trim) to reach Zero G normal load factor or, if limited by elevator control authority, the lowest load factor obtainable at the target speed, as the airplane's pitch attitude passes approximately through level flight (that is, through the horizon).

- Trim speed  $1.23 V_{SR}$ , target speed not more than  $1.23 V_{SR}$ , or
- Trim speed  $V_{FE}$ , target speed not less than  $V_{FE} - 20$  knots.

Perform this maneuver with idle power or thrust and with go-around power or thrust.

# The Flight Test Maneuver

Conduct steady heading sideslips to full rudder input, 180 pounds rudder force, or full lateral control authority (whichever comes first) at a trim speed of  $1.23 V_{SR}$  and the power or thrust for minus  $3^\circ$  flight path angle.

# The Flight Test Maneuver for $\frac{1}{2}G$ Pushover

At most critical CG, trim the airplane at the specified speed, conduct a pull-up maneuver to 1.5 G and pushover maneuver to 0.5 G to evaluate that longitudinal control forces do not reverse.

(Requires a G-Meter.)

High lift devices retracted configuration (or holding configuration if different), holding speed, power or thrust for level flight.

Landing configuration,  $V_{REF}$  for non-icing conditions, power or thrust for landing approach. If necessary, limit the pull-up maneuver to the point at which stall warning occurs.

# The Flight Test Maneuver

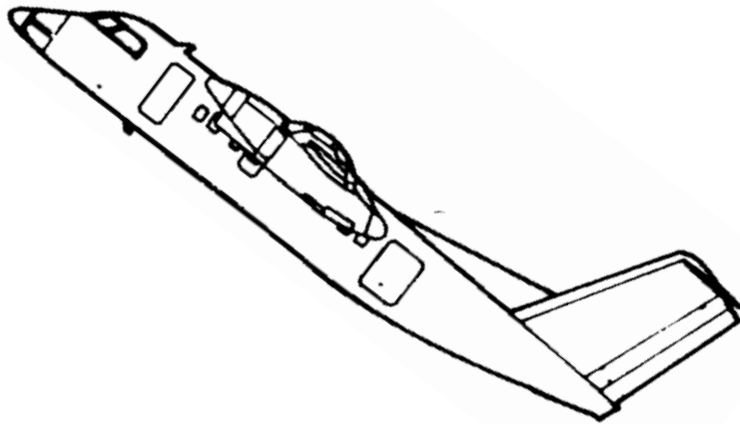

- Climb to enter pushover from a moderate pitch attitude.

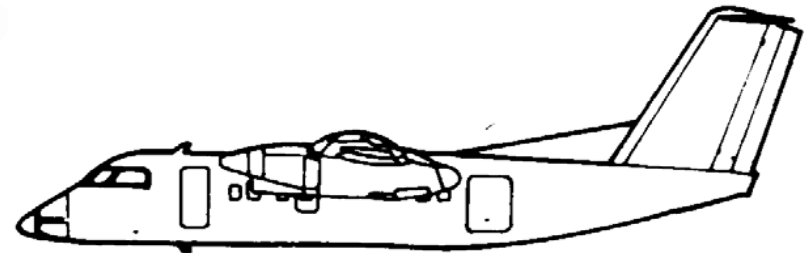

- Configuration Set
- Power for Trim Speed
- Trim at Trim Speed

# The Flight Test Maneuver

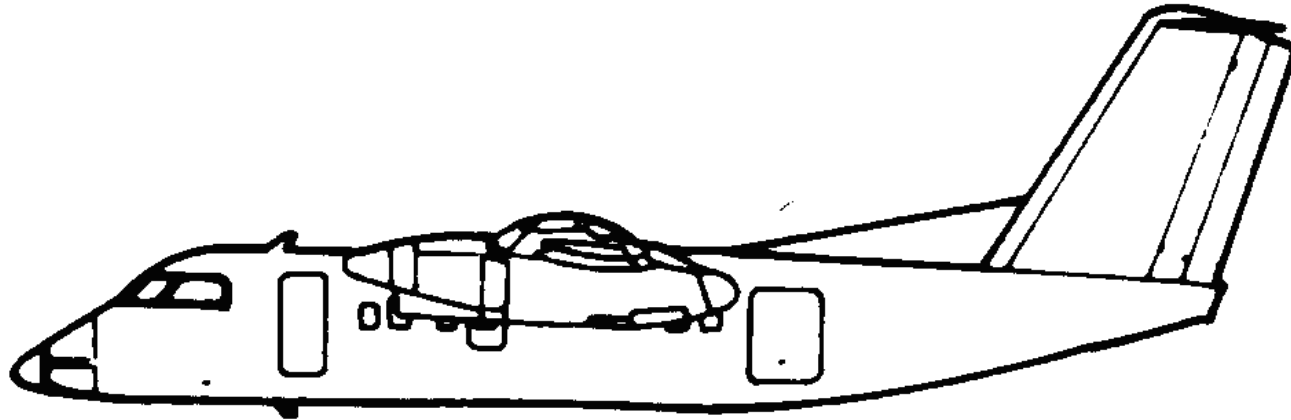

- Push to achieve level flight at Target Speed and Target G.

# The Flight Test Maneuver

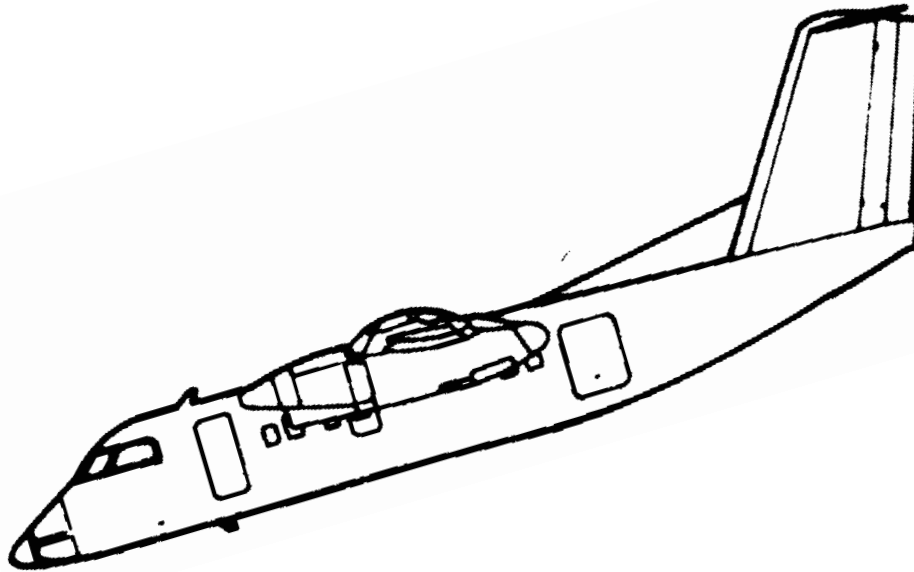

- Pull 1.5 G to recover to level flight.
- Evaluate control forces with 50 pound criteria.

# Power Requirements

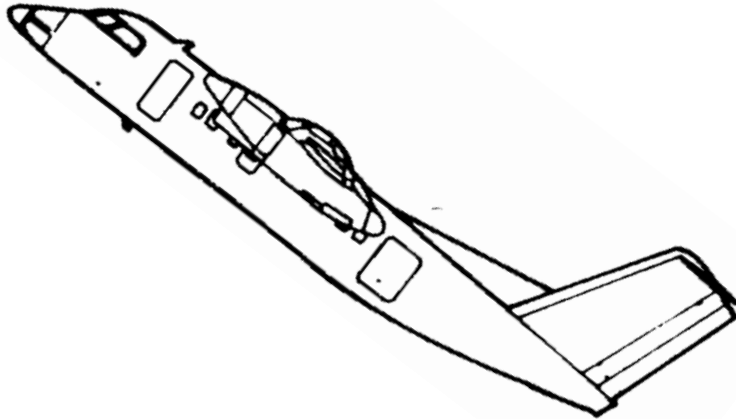

- Configuration Set
- Go Around Power Set
- Trim at Trim Speed
- Continue climb to enter pushover

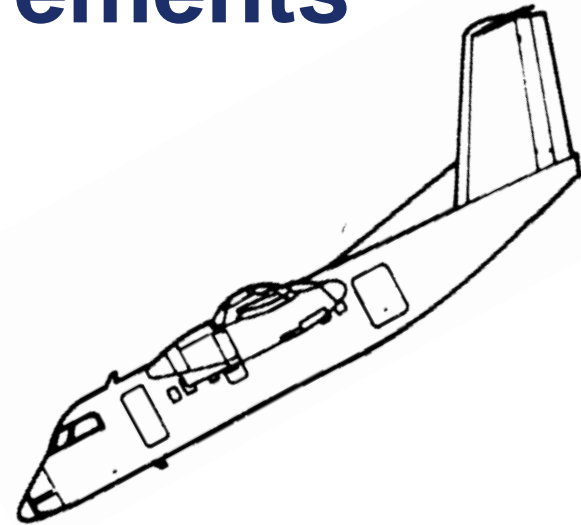

- Configuration Set
- Power Idle Set
- Trim at Trim Speed
- Add power to climb
- Reduce power entering pushover

# Flight Test Risk Assessment

**Flight Tests in Icing Conditions, or Flight Tests with Ice Accretions or Ice Shapes are considered by the FAA to be High to Medium Risk.**

# Flight Test Safety

## Pushover Maneuver

- **Build up to final target G**
- **Respect control force reversal tendency**
- **If control force is unacceptable**
  - Reduce wing flap
  - Reduce power
  - Increase wing AoA: **pull up**

# Roll Control Anomalies

- **Aerodynamics similar to ICTS**
- **Complicated by aileron design and opposite aileron coupling**
  - Aileron design to reduce hinge moment and roll control force
    - Aileron deflection angles
    - Servo – trim tabs
    - Aerodynamic balance “horns”
    - Ice protection systems

# Flight Test Evaluation of Roll Control

- **Ice Shapes on Wing**
- **Increase wing AoA**
  - Pull Ups
  - Wind Up turns

# **Flight Test Safety**

## **Roll Control Evaluation**

- **Build up to final target G**
- **Respect control force reversal tendency**
- **If control force is unacceptable**
  - Reduce AoA
  - Increase power
  - Level wings

**Opposite the recovery from ICTS !**

# Summary

- ICTS has been a major factor in accidents and incidents.
- The flight test maneuvers to evaluate susceptibility to ICTS are mostly quantitative and require little instrumentation.
- Roll control evaluations are similar to ICTS but control systems may be more complex.
- Flight Test Risks can be mitigated.