

2012 SAE SUPERMILEAGE® RULES

TABLE OF CONTENTS

INTRODUCTION	2
PART A – ADMINISTRATIVE REGULATIONS	3
ARTICLE 1: SAE SUPERMILEAGE OVERVIEW	3
ARTICLE 2: RULES	3
ARTICLE 3: INDIVIDUAL PARTICIPATION REQUIREMENTS.....	4
ARTICLE 4: FACULTY ADVISOR.....	6
ARTICLE 5: VEHICLE ELEGIBILITY.....	6
ARTICLE 6: REGISTRATION.....	6
ARTICLE 7: AWARDS	7
ARTICLE 8: QUESTIONS	8
PART B – TECHNICAL REQUIREMENTS.....	9
ARTICLE 1: GENERAL DESIGN REQUIREMENTS.....	9
ARTICLE 2: ENGINE AND POWERTRAIN	11
ARTICLE 3: FUEL AND FUEL BOTTLE	13
ARTICLE 4: PRESSURIZED FUEL SYSTEM.....	14
ARTICLE 5: ELECTRICAL SYSTEMS.....	15
ARTICLE 6: VEHICLE STRUCTURE.....	16
ARTICLE 7: BRAKE SYSTEM	17
ARTICLE 8: DRIVER EQUIPMENT	18
ARTICLE 9: EQUIPMENT REQUIREMENTS	19
ARTICLE 10 - NOTICE OF POSSIBLE FUTURE RULE CHANGES	20
PART C – STATIC EVENTS.....	21
ARTICLE 1: DESIGN REPORTS.....	21
PART D – DYNAMIC EVENT	24
ARTICLE 1: PERFORMANCE RUN.....	24
ARTICLE 2: GENERAL CONDUCT AND REGULATIONS.....	25
ARTICLE 3: COMPLAINTS AND PROTESTS	25
APPENDIX A.....	27
APPENDIX S	28

2012 SAE SUPERMILEAGE® RULES

INTRODUCTION

This introduction is intended to highlight some aspects of the 2012 SAE Supermileage Rules that you may find of interest. These highlights touch on only part of the revised text and do not replace or change the Rules.

Caution - Neither this introduction, nor any other summary, is a substitute for reading and understanding the Rules. The Rules are a reference document and should be used for that purpose. Do not attempt to design your vehicle based on the parts of the Rules you happen to remember from the last time you read them. We cannot stress it too strongly – read the Rules thoroughly and repeatedly.

Registration Opening – The first day of registration for Supermileage has been shifted to Tuesday. For the 2012 Supermileage online registration will open at 10:00am EDT Tuesday, October 4, 2011.

B5.1 Batteries – The use of batteries based on lithium chemistry has been regulated.

B6.5 Excitability - Taping the edges of the body panels above the driver is prohibited.

PART A – ADMINISTRATIVE REGULATIONS

ARTICLE 1: SAE SUPERMILEAGE OVERVIEW

A1.1 Supermileage Competition Objective

The objective of the SAE Supermileage competition is to offer undergraduate and graduate students the opportunity to enhance their engineering design and engineering project management skills in a challenging competition.

A1.2 Design Goal

The engineering design goal for SAE Supermileage is to develop a single person, extremely high mileage vehicle that complies with the Supermileage rules. The vehicles will run a specified course with the vehicle obtaining the highest combined kilometers per liter (miles per gallon) rating plus design segment points winning the event.

A1.3 Good Engineering Practices

Vehicles entered into SAE Supermileage competitions are expected to be designed and fabricated in accordance with good engineering practices.

ARTICLE 2: RULES

A2.1 Rules Authority

The SAE Supermileage Rules are the responsibility of the SAE Supermileage Rules Committee and are issued under the authority of the SAE University Programs Committee. Official announcements from the SAE Supermileage Rules Committee, SAE or the Supermileage organizers shall be considered part of and shall have the same validity as these rules.

A2.1.1 Ambiguities or questions concerning the meaning or intent of these rules will be resolved by the SAE Supermileage Rules Committee, SAE staff or by the individual competition organizers as appropriate.

A2.2 Rules Validity

The SAE Supermileage Rules posted on the SAE website and dated for the calendar year of the competition are the rules in effect for the competition. Rule sets dated for other years are invalid.

A2.3 Rules Compliance

By entering a SAE competition the team, members of the team as individuals, faculty advisors, and other personnel of the entering university agree to comply with, and be bound by, these rules and all rule interpretations or procedures issued or announced by SAE, the SAE Supermileage Rules Committee, and the other organizing bodies.

Any rules or regulations pertaining to the use of the competition site by teams or individuals and which are posted, announced and/or otherwise publically available are incorporated into the Supermileage Rules by reference. As examples, all event site waiver requirements, speed limits, parking and facility use rules apply to Supermileage participants.

All team members, faculty advisors and other university representatives are required to cooperate with, and follow all instructions from, competition organizers, officials, and judges.

A2.4 Understanding the Rules

Teams are responsible for reading and understanding the rules in effect for the competition in which they are participating. The section and paragraph headings in these rules are provided only to facilitate reading; they do not affect the paragraph contents.

A2.5 Participating in the Competition

Teams, team members as individuals, faculty advisors and other representatives of a registered university who are present on-site at a competition are considered to be “participating in the competition” from the time they arrive at the event site until they depart the site at the conclusion of the competition or earlier by withdrawing.

A2.6 Official Communications

All teams are required to read and follow official announcements concerning the competition and the rules that are sent from the SAE or organizers to the team captain and/or faculty advisor.

Official announcements from SAE will be posted to the SAE Supermileage Forum at http://forums.sae.org/access/dispatch.cgi/supermileage_pf. Information will also be posted on the SAE Supermileage website at <http://www.sae.org/students/supermw.htm>.

A2.7 SAE Technical Standards Access

A cooperative program of SAE’s Education Board and Technical Standards Board is making some of SAE’s Technical Standards available to teams registered for any North American Collegiate Design competition at no cost. The Technical Standards referenced in the Collegiate Design Series rules, along with other standards with reference value, will be accessible online to registered teams, team members and faculty advisors. To access the standards (1) your team must be registered for a competition in North America and (2) the individual team member or faculty advisor wanting access must be linked to the team in SAE’s system.

Access Procedure - Once your team has registered there will be a link to the technical standards titled “Design Standards” on the main registration screen where all the required onsite insurance information is added. On the technical standards webpage you will have the ability to search standards either by J-number assigned or topic of interest such as brake light.

A list of the accessible SAE Technical Standards can be found in Appendix S.

ARTICLE 3: INDIVIDUAL PARTICIPATION REQUIREMENTS

A3.1 Eligibility Limits

Eligibility is limited to undergraduate and graduate students to insure that this is an engineering design competition.

A3.2 Student Status

Team members must be enrolled as degree seeking undergraduate or graduate students in a college or university. Team members who have graduated during the seven (7) month period prior to the competition remain eligible to participate.

A3.3 SAE Membership

Team members must be members of SAE. Proof of SAE membership is required at the event. Information on SAE Student membership can be found on SAE’s website:

www.sae.org/students

A3.4 Age

Team members must be at least eighteen (18) years of age.

A3.5 Driver's License

Team members who will drive a competition vehicle at any time during a competition must hold a valid, government issued driver's license.

A3.6 Liability Waiver

All on-site participants, including students, faculty, volunteers, and supporters are required to sign one or more liability waiver(s) upon registering on-site.

A3.7 Insurance

Individual medical and accident insurance coverage is the sole responsibility of the participant and is **REQUIRED**.

A3.8 Individual Registration Requirements for North American Competitions – ACTION REQUIRED

A3.8.1 All students and faculty, both domestic and international, if you have an SAE International membership, make sure you are affiliated to your respective school/ college/ university on the SAE website under your "MySAE".

A3.8.2 If you are not a member of SAE International or other approved societies, you will need to join SAE International online at www.sae.org. Select the "Join /Renew/Upgrade" link under the Membership tab, and then select "Professional or Student". Students will need to select the "Student Membership" link and then follow the series of the questions that are asked. Faculty that wishes to be SAE members should choose the "Professional Membership" link and proceed to the series of questions. Please note all student participants must be SAE International members to participate in the event. It is not mandatory for faculty to join.

A3.8.3 All international student participants (or unaffiliated faculty advisors) who are not SAE International members are required to complete the International Student Registration form for the entire team found in the specific event registration webpage. Upon completion, email the form to CollegiateCompetitions@sae.org stating which event and university name.

A3.8.4 **Online registration information is required!** Every participant, including advisors must affiliate themselves and complete the following information on under the team's registration page on the SAE website:

- Medical insurance confirmation
- Driver's license confirmation
- Emergency contact data (point of contact (parent/guardian, spouse), relationship, and phone number)

To do this you will need to go to "Registration" page under the specific event the team is registered and then click on the "Register Your Team / Update Team Information" link. At this point, if you are properly affiliated to the school/college/university, a link will appear with your team name to select. Once you have selected the link, the registration page will appear. Selecting the "Add New Member" button will allow individuals to include themselves with the rest of the team. This can also be completed by team captain and faculty advisor for all team members.

All students, both domestic and international, must affiliate themselves online or submit the International Student Registration form by March 1, 2012. For additional assistance, please contact CollegiateCompetitions@sae.org.

A3.8.5 Onsite Registration Requirement

ONSITE REGISTRATON IS REQUIRED OF ALL TEAM MEMBERS AND FACULTY ADVISORS.

Bring your (1) Government issued driver's license or passport and (2) your medical insurance card or documentation to onsite registration.

ARTICLE 4: FACULTY ADVISOR

A4.1 Status

Each team is expected to have a Faculty Advisor appointed by the respective university. The Faculty Advisor is expected to accompany the team to the competition and will be considered by competition officials to be the official university representative.

A4.2 Responsibilities

Faculty Advisors may advise their teams on general engineering and engineering project management theory.

A4.3 Limitations

The faculty advisor may not design any part of the vehicle nor directly participate in the development of any documentation or presentation. Additionally, Faculty Advisors may neither fabricate nor assemble any components nor assist in the preparation, maintenance, testing or operation of the vehicle.

In short: Faculty advisor may not design, build or maintain the vehicle.

ARTICLE 5: VEHICLE ELEGIBILITY

A5.1 Student Developed

The vehicle must be conceived, design and fabricated by the team members without direct involvement from professional engineers, faculty and technical staff in the college/school or professionals in the motorsports community. The team should be prepared to discuss/explain their design if asked to do so by the Supermileage Organizers.

A5.2 Professional Fabrication Limits

Vehicles that have been professionally fabricated may be disqualified from the competition. If a team lacks access to machine shop facilities, a reasonable number of components may be professionally fabricated without penalty. The team should be prepared to document such lack of fabrication facilities.

A5.3 Re-entered Vehicles/Engines

To ensure a genuine design effort, significant modifications to a previous year's entry must be made.

ARTICLE 6: REGISTRATION

A6.1 Registration

Registration for SAE Supermileage must be completed online.

A6.2 Registration Dates

Registration opens online on Tuesday, October 4, 2011 at 10:00 am EDT. Registration closes on Monday, December 19, 2011 at 11:59 pm EST.

A6.3 Registration Fee

The registration fee indicated in the Appendix must be paid online by credit card at the time of online registration. Registration fees may not be paid by any other means.

Registration fees are NOT refundable, nor deferrable to future competitions.

A6.4 United States Visas

Teams requiring visas to enter to the United States are advised to apply at least sixty (60) days prior to the competition. Although most visa applications seem to go through without an unreasonable delay, occasionally teams have had difficulties and in several instances visas were not issued before the competition.

Don't wait – apply early for your visa.

Neither SAE staff nor any competition organizers are permitted to give advice on visas, customs regulations or vehicle shipping regulations concerning the United States or any other country.

A6.5 Registration Acknowledgement

If your team has registered for the Supermileage competition then SAE can provide an acknowledgement of your registration. SAE does not issue letters of invitation.

A6.6 Vehicle Shipping

Vehicle shipments by commercial carrier must comply with the laws and regulations of nations from which, and to which, the car is being sent. The process for shipping a vehicle can be complex and lengthy. Teams are advised to consult with their shipping company or freight forwarder to be sure their shipment fully complies with all relevant, customs, import/export and aviation shipping requirements.

Shipments must be sent with the sending team or university listed as the receiving party. Neither the competition organizers nor the competition site can be listed as the receiving party.

A6.7 Onsite Registration

All team members and faculty advisors must complete the on-site registration procedures immediately after they arrive at the competition site.

On-site registration must be completed and any credentials and/or other identification issued by the organizers properly worn before the car can be unloaded, uncrated or worked upon in any manner.

ARTICLE 7: AWARDS

The following awards will be made at the SAE Supermileage® Competition:

A7.1 First Place Awards

An award will be given to the team with the top overall score. This will be determined by the sum of the points earned on the Design Report added to the fuel mileage.

A7.2 Additional Awards

Awards will be given for the teams achieving the top scores. Additional teams will receive a financial award proportional to the individual team overall score provided a successful, positive fuel economy run is achieved.

A7.3 Design Award

An award will be given for the team with the highest Design Report score.

ARTICLE 8: QUESTIONS

A8.1 Rules Questions & General Comments

Any questions or comments about the rules should be brought to the attention of the organizing committee as soon as possible to prevent misconceptions about the competition proceedings or intentions. All correspondence should be sent to the event organizers.

A8.2 General Information

General information about hotels and other attractions in the area as well as a schedule of events will be provided to registered teams.

PART B – TECHNICAL REQUIREMENTS

ARTICLE 1: GENERAL DESIGN REQUIREMENTS

B1.1 General Configuration

The vehicle must have a minimum of three wheels contacting the ground at all times. Vehicle length, width, and height are not expressly regulated. The driver must be fully enclosed within the body of the vehicle to prevent driver contact with the pavement.

B1.2 Vehicle Power Limitations

The sole source of vehicle propulsion must be from the four-cycle engine. This means no human power system, no sail, etc. Any inertial system, if used, must be at rest prior to the start of the performance run.

B1.2.1 All energy used for propulsion of the vehicle must come from the fuel.

B1.3 Driver Position

The driver must be seated in the vehicle so that his/her feet are forward in the vehicle pointing in the direction on travel. Drivers may **not** be positioned head forward in the vehicle.

B1.4 Forward Field of Vision

The driver must have adequate visibility to maintain control and have situational awareness. Forward field of vision not less than +/- 80° from the vehicle longitudinal axis is required.

B1.4.1 Windscreens - Vehicle windscreens, if so equipped, must be treated with a water beading agent on the exterior and an anti-fogging agent on the interior.

Figure 1 - MINIMUM VISIBILITY PLANE

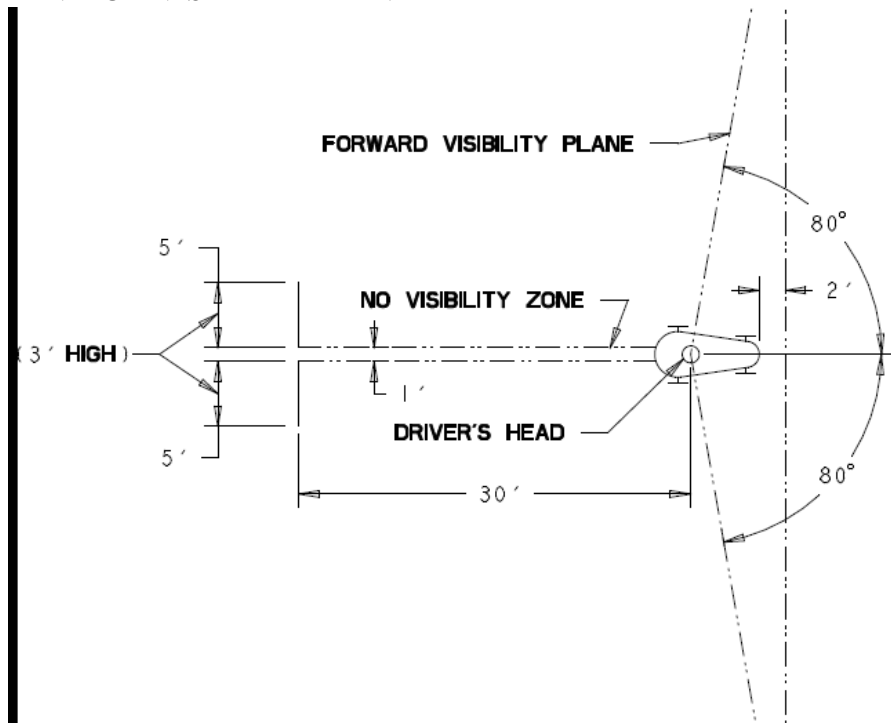

B1.4.2 Forward Visibility - When in the normal driving position, the driver must be able to see and recognize objects on the ground 6.0 m (20 ft.) in front of the vehicle.

B1.5 Maneuverability

B1.5.1 Each vehicle must have steering geometry capable of a 15.2 m (50 feet) maximum inside turning radius. Vehicle maneuverability will be evaluated during Technical Inspection using the maneuverability course described in Figure 2.

Figure 2 - Maneuverability Course

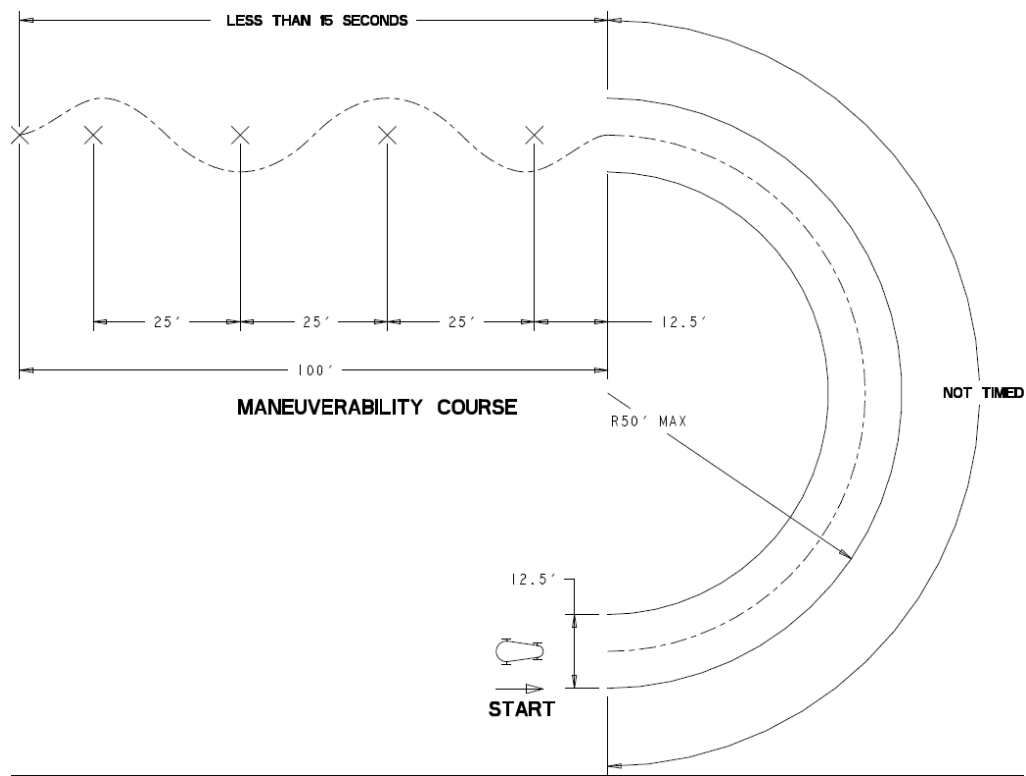

Slalom Section: Vehicle must traverse 30.5 meters (100 feet) slalom section in less than 15 seconds. Pylon spacing will be 7.6 meters (25 feet)

B1.5.2 Steering must be through a “natural” response steering system: The driver will move the steering interface device to the right to make the vehicle turn right and the driver will move the steering interface device to the left to make the vehicle turn left.

B1.6 Stability

B1.6.1 Each vehicle will be required to demonstrate its lateral stability.

B1.6.2 The vehicle, with every qualified driver for the team with all equipment necessary to meet the driver weight and safety regulations, must maintain full wheel contact with a ramp of **twenty (20) degrees** (measured from horizontal) when located statically on the ramp to the following configuration: one front wheel and one rear wheel of the vehicle must contact a horizontal line 2.4 m (8 ft.) long on the ramp with the vehicle in full right and left turn configuration. No supporting structure or wheel contact is permitted on the ramp below the horizontal line.

B1.6.3 Vehicle stability will also be evaluated during technical inspection using the slalom part of the maneuverability course described in Figure 1 above.

B1.7 Minimum Driver Weight

B1.7.1 Minimum driver mass is 59kg (130 pounds) fully equipped and with a helmet. Drivers who do not meet the minimum weight requirements must provide ballast to bring their weight up to 59kg (130 pounds)

B1.7.2 Ballast attached to the driver cannot exceed 4.5kg (10 pounds). Driver’s belt or similar weights are suggested. Other ballast not attached to the driver must be both (1) rigidly fixed to the vehicle when in operation and (2) removable for weighing.

ARTICLE 2: ENGINE AND POWERTRAIN

B2.1 Base Engine

BRIGGS & STRATTON 3.5 HP MODEL 091202 TYPE 1016E1A1001

For over twenty years, the Briggs & Stratton Corporation has generously provided engines to the SAE Supermileage teams without charge.



All vehicles must use the same base engine supplied to each entrant by Briggs & Stratton Corporation (Model 091202 Type1016E1A1001 or similar). The engine is air cooled, four cycle, with a 2.61 kW (3.5 horsepower) rating at 3600 rpm. Changes to the base engine, which may be desired for improved efficiency, are acceptable but must satisfy the requirements of B2.3 “Engine Modifications”.

B2.2 Engine Eligibility

Teams will be eligible to receive a new Briggs & Stratton engine every year. Teams **MUST** order the engines separately online once they've registered for the event. For assistance please contact collegiatecompetitions@sae.org. Engines will only be delivered to addresses in North America.

B2.3 Engine Modifications

The base Briggs & Stratton engine may be modified in any manner that otherwise complies with these rules with the following exceptions.

B2.3.1 Cylinder & Crankcase

The cylinder and crankcase must be identifiable as components of the base engine supplied by Briggs & Stratton to the entrant.

B2.3.2 Crankshaft Support Bearings

The crankshaft support bearings (journals) may be altered or replaced but must be retained solely by the Briggs & Stratton crankcase.

B2.3.3 Piston Friction Surface

The piston friction surface may be altered or replaced but must be retained solely by the Briggs & Stratton crankcase.

NOTE: Encapsulating another manufacturer's engine within the Briggs & Stratton cylinder/crankcase assembly is in violation of these rules.

B2.3.4 Crankcase Ventilation

Crankcase cannot be ventilated to engine intake air.

B2.4 Transmission and Clutch

Transmission and/or clutch design must be such that the engine can be disconnected from the driving wheels so as to allow the vehicle to be stationary with the engine running.

B2.5 Exhaust System

Engine exhaust must exit the body (if so equipped). Mufflers are not required. Exhaust pipe's entire external surface must be insulated or guarded to reduce the risk of burns.

The exhaust pipe must extend a minimum of 25 mm (1.0 inch) beyond the outside of the body of vehicle.

B2.6 Guards and Shields

B2.6.1 All moving powertrain components must be guarded to prevent damage to fuel carrying components and prevent injuries to the driver in the event that breakage should occur. Shielding should also protect against any potential contact with the driver or support personnel when components are moving.

B2.6.2 If wheels are inside body shell, they must be shielded to prevent propulsion by the driver.

B2.6.3 All vehicles must have a belly pan that completely separates the driver from incidental contact with the pavement.

B2.6.4 All fuel system components must be guarded or restrained to prevent contact with moving parts.

B2.6.5 All electrical components must be guarded and/or restrained to prevent contact with moving parts and prevent abrasion of the insulation.

ARTICLE 3: FUEL AND FUEL BOTTLE

B3.1 Fuel

The fuel will be iso-octane (2, 2, 4 –trimethylpentane) to provide uniform fuel composition.

B3.2 Fuel Bottle

The fuel bottle must be mounted vertically to avoid fuel leakage from the vented cap. The bottle must be readily accessible with all body panels in place. Access doors are preferred.

Figure 3 shows the fuel bottle that will be used in the competition. The competition organizer provides the competition fuel bottle for each fuel economy attempt.

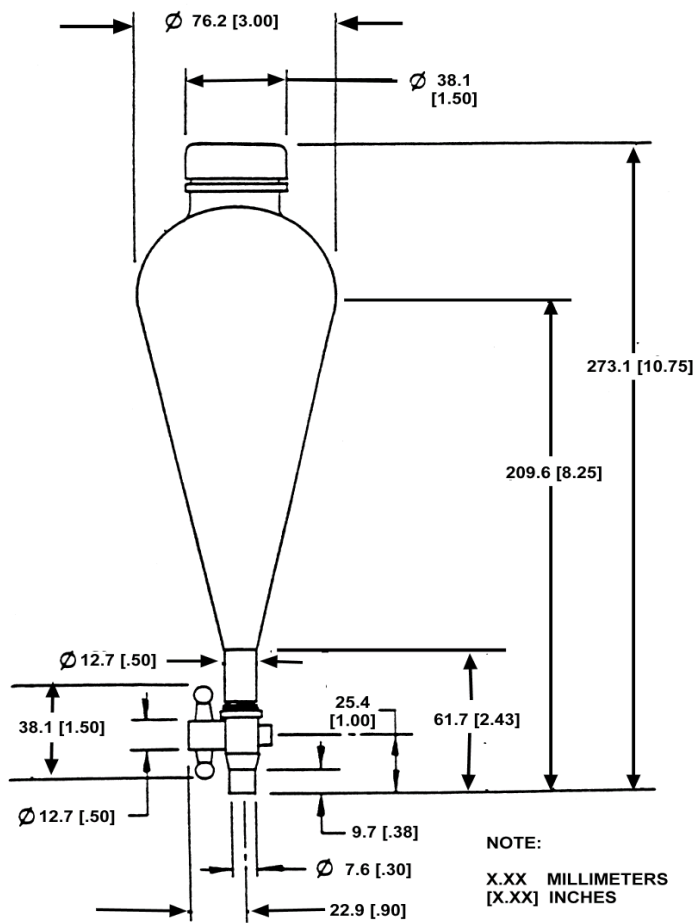

FIGURE 3 – FUEL BOTTLE
Separatory Funnel 250 ml

Cole-Parmer Instrument Company Catalog
Number AP-06125-20 (Teflon Fep) or Number AP-06126-20 (Polypropylene)

B3.3 Fuel Bottle Retainment

The fuel bottle must be positively retained. The fuel bottle cannot be retained in its holder using adhesive tape. The bottle must be rigidly retained to prevent fuel spillage. Figure 3 shows the fuel bottle that will be used in the competition.

B3.4 Access Door(s)

B3.4.1 Access door(s) for fuel bottle installation and removal must be of a sufficient size to permit easy insertion and placement of the fuel bottle.

B3.4.2 The existing fuel bottle must be able to be replaced with a new bottle within 45 seconds. The 45 seconds includes placement of the bottle, fuel line attachment, and securing of all body features to achieve a state of “ready to run.”

B3.4.3 Rear body sections of the vehicle that are hinged on the engine-side of the firewall are acceptable. Complete removal of the access door, complete removal of a body panel from the vehicle, or access panels and doors hinged on the driver-side of the firewall are unacceptable.

B3.4.4 Experience has shown that access doors in the shape of a square with a minimum side length of 20 cm (8 inches) allow sufficient access for placement of the fuel bottle.

B3.4.5 Participants will be required to demonstrate the 45 seconds compliance during Technical Inspection.

B3.5 Fuel System Drainage

Fuel and lube system should be designed so that loss of fluids will not result in a fire hazard. Positive drainage away from the driver and out of the vehicle is required in all areas where fuel is present or could leak.

B3.5.1 All push-on fuel line fittings must be clamped.

ARTICLE 4: PRESSURIZED FUEL SYSTEM**B4.1 Pressurized Fuel Tanks – Prohibited**

Pressurized fuel tanks are prohibited.

B4.2 Pressurized Fuel Systems

Pressurized fuel systems are permissible. The following requirements are for pressurized fuel systems only.

B4.3 Hose

Tubing pressure rating (or specification designation) must be clearly marked by the tubing manufacturer on tubing. Pressure rating must be suitable for the pressure being used.

B4.4 Markings

Vehicles using pressurized fuel must mark the vehicle with the letters EFI. The lettering must be at least 25mm (1 inch) high and clearly visible on the outside of the vehicle adjacent to the fuel door.

B4.5 Pressure Gauge

A pressure gauge must be provided for display of fuel pressure. The gauge must be clearly visible through the fuel access door during fuel bottle insertion and removal.

B4.6 Dump Valve

A dump valve must be provided for depressurizing the fuel system before and after fuel bottle replacement. The valve must be easily accessible through the fuel access door.

B4.6.1 Dump valve must be labeled with letters at least 13mm (0.5 inches) high.

ARTICLE 5: ELECTRICAL SYSTEMS**B5.1 Batteries**

Batteries can be carried in each vehicle but are limited to starting systems, ignitions, instrumentation, and the like. Batteries must in no way be capable of powering the vehicle.

B5.1.1 All batteries must be securely and rigidly mounted to the vehicle. Note: Batteries are not considered to be ballast for the purpose of meeting the required driver weight (Rule B1.7)

B5.1.2 All battery cells or battery packs (groups of battery cells) based on lithium chemistry, must be separated from the driver by a firewall and protected from any heat sources

B5.1.3 Battery packs based on Lithium Chemistry

- a. Must be commercially manufactured items.
- b. Must have over voltage, under voltage, short circuit and over temperature protection.
- c. Must be presented at Technical Inspection with markings identifying the battery for comparison to the manufacturer's datasheet or other equivalent documentation proving the pack and supporting electronics meet all rules requirements.

B5.2 Starting Systems, Lights

Batteries used for starting systems can be of any size and voltage. They must be electrically separate from all other systems. They can only be used for starting the engine and powering lights.

B5.3 Other Vehicle Electrical Systems

All other electrical items (fuel pumps, injectors, ignition, instrumentation, etc.) must use a 12V battery with a C20 rated capacity no larger than 1.4 Ah. An engine driven generator may be required to keep the battery charged if power consumption is high.

B5.4 Fuse Requirements

All electrical connections to any batteries MUST be fused with an appropriately rated fuse.

B5.5 Self Contained Devices

Team communication, stopwatches, bicycle computers, or similar devices that have self-contained battery sources are permissible and are not governed by the above battery restrictions.

B5.6 Kill Switch(es)

B5.6.1 Three (3) kill switches grounding the engine ignition are required. One must be mounted within easy reach of the driver, and one must be mounted on each side of the vehicle.

- B5.6.2 All kill switches must be of a positive action, toggle type - toggle lever arm must be a minimum 19.0 mm (0.75 inches) long. Momentary contact or rocker type switches are prohibited.
- B5.6.3 The external kill switches must be securely mounted on the frame or a rigid body section. Switches must be mounted on the body between the front wheel and the rear of the vehicle at least 76.2mm (3 inches) above the ground.
- B5.6.4 To ensure that the kill switches remain intact in the event of a lost body element, the external kill switches may not be mounted on removable, or flexible, body panels or sections. In addition, switches must not be mounted on surfaces curving under the vehicle.

NOTE: All kill switches must also shut off any installed electric fuel pump(s).

- B5.6.5 All kill switches must be clearly labeled with "run" and "kill" positions in a color which contrasts with the mounting surface. External switches must use lettering at least 38.1 mm (1.5 inches) high and internal switches must use lettering at least 12.7 mm (0.5 inches) high.

B5.6.7 Throttle Control by Wire

B5.7.1 The engine throttle can be controlled electrically. Provided at least one (1) of the following conditions is met:

- (1) The fuel system will immediately return to a closed throttle condition if any part of the electrical system fails.
- (2) The kill switch circuit must leave the engine inoperable if any portion of the kill circuit fails. This includes wire breakage and electrical short to chassis.

B5.6.8 Automatic Engine Starting – Prohibited

An electric starter may not be initiated by any means other than the driver. An automatic system may be used to signal the driver when to start the engine but may not initiate any part of the start sequence.

ARTICLE 6: VEHICLE STRUCTURE

B6.1 Roll Hoop

A "roll hoop" is required and must be made of substantial material. The device must extend a minimum of 5 cm (2 inches) above the tallest driver's helmet. Also in the driving position, some portion of the driver's helmet must be within 10 cm (4 inches) of this device - as also shown in Figure B.

B6.2 Roll Hoop Width

The roll hoop must extend wider than the shoulders of any driver of the vehicle, at or above the drivers shoulders – an example of which is shown in Figure A.

B6.3 Roll Hoop Strength

The roll hoop, as fitted to the vehicle, must be able to withstand a 114 kg (250 lb.) force applied to it. The location and direction of the 114 kg (250 lb.) force may come from any of the directions shown in Figure 4C. The roll hoop also cannot deflect so much as to cause noncompliance with the above roll protection device requirements.

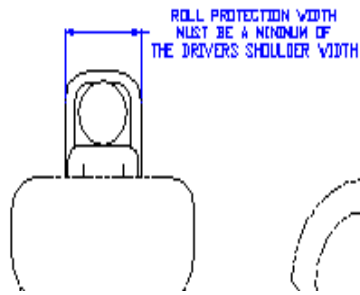

Figure 4A

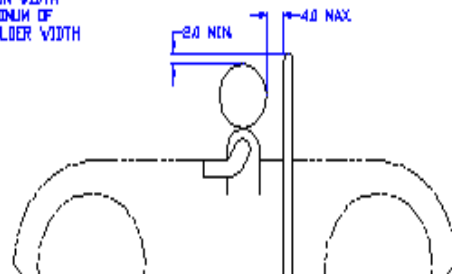

Figure 4B

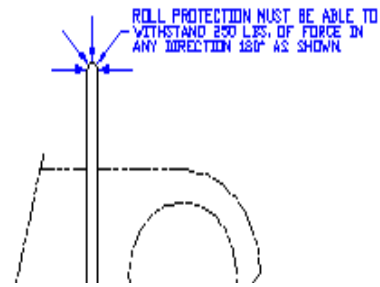

Figure 4C

B6.4 Fire Wall

- B6.4.1 A wall of steel or aluminum material of 0.813 mm (0.032 inches) minimum thickness must completely separate the operator from the engine. Furthermore, the firewall must not interfere with the operation and use of the fire extinguisher. The firewall must extend to top of driver's helmet.
- B6.4.2 No openings larger than 13 mm (0.5 inch) in diameter will be permitted in the firewall. This includes gaps between the firewall and body.
- B6.4.3 Any wires/lines passing through the firewall must be provided with effective protection against abrasion through the use of grommets, thick tape around sharp edges, etc.

B6.5 Exit ability

- B6.5.1 The driver must be able to exit the vehicle within 15 seconds, unassisted, in case of an emergency. A maximum of two support personnel must also be able to quickly extract a driver from a vehicle without assistance from the driver within 20 seconds. Exit ability will be tested during Technical Inspection. Exit ability for every driver for the team will be tested during Technical Inspection.
- B6.5.2 Any latches, catches, removable parts or similar items that are used to assist driver removal by support personnel must be (1) clearly marked "Access" and (2) color coded with a minimum of 6.5 cm² (1 inch²) of fluorescent orange and be readily visible from outside the vehicle.

All loose wires/hoses/lines within the driver's compartment must be retained so as to eliminate interference with exit ability or driver movement during the operation of the vehicle.

- B6.5.2 Tape **may not** be used to attach body panels, or to seal gaps between panels or structure, in a manner that may interfere with the driver's ability to exit the vehicle.

ARTICLE 7: BRAKE SYSTEM

B7.1 Brake Requirement

Each vehicle must be equipped with a brake system which is capable of stopping the vehicle containing any team driver within 4.0 meters (13.12 feet) in a reasonably straight line when traveling at 24kph (15mph).

B7.2 Brake Actuator Location

The brake actuator must be mounted to the interior of the vehicle. The brake actuator may not be

mounted to any body panel. The driver must have access to the brake actuator at all times.

B7.3 Brake Test

The brake system will be tested to determine if it is capable of decelerating the vehicle from 24 kph (15 mph) at a rate greater than 0.25 g (gravity). Brake system performance will be evaluated at Technical Inspection using the course shown in Figure 5.

- a) Acceleration zone: There will be a minimum of 50m (164 feet) available for the vehicle to accelerate to a minimum speed of 16 kph (10mph).
- b) Coast zone: The vehicle must traverse the coast zone in less than 1.5 seconds.
- c) Brake zone: The vehicle must come to a complete stop within the brake zone.

Figure 5 - Brake Evaluation

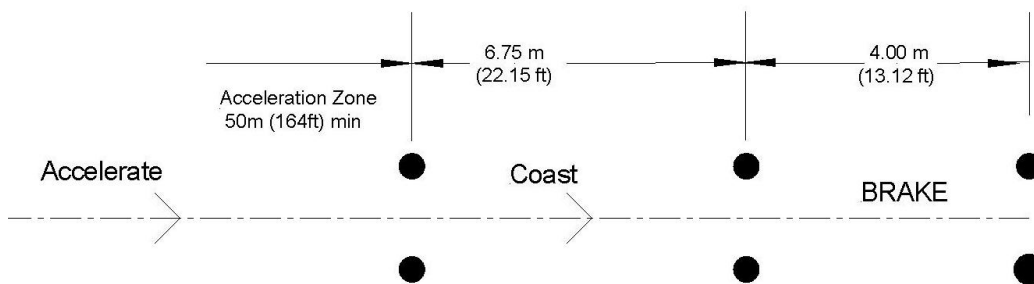

B7.4 Brake Light

The vehicle must be equipped with a brake light (Reference SAE J586). The brake light must be clearly visible to the driver of any vehicle entered into the Supermileage competition under all lighting and potential weather conditions.

The referenced standard will be available online by SAE once individuals have registered for the competition. Only those who have their name registered to a team will have access to the standard. See Rule A2.6.

ARTICLE 8: DRIVER EQUIPMENT

B8.1 Driver Restraint Harness

A minimum 3-point driver harness is required. This 3-point harness must include two lap belt points and one point connecting a belt (or two belts) supporting the upper body. The use of one upper body support would need to be a cross-belt (similar to a passenger vehicle), whereas two shoulder belts could be used attached at the uppermost point as well.

B8.2 4, 5 or 6 Point Harnesses

The use of a 4 point, 5 point or 6 point harnesses, or any belt system that exceeds the minimum requirement is allowed.

B8.3 Single Release

All driver restraint belts must use a single release common to the lap belt(s) and upper body belt or harness using a metal to metal quick release latch.

B8.4 Belt Attachment Points

The belt attachment points must be strong enough that the vehicle could be lifted by them.

B8.5 Driver's Gear

The following equipment must be worn anytime a driver is seated in the vehicle and the engine is running or being started:

B8.5.1 Helmet

A well-fitting helmet with an integrated (one piece composite shell) meeting one of the following standards and labeled as such: Snell K2000, K2005, K2010, M2000, M2005, M2010, SA2000, SA2005, SA2010, or British Standards Institution BS 6658-85 types A or A/FR rating. Hard-shell bicycle helmets are not allowed.

B8.5.2 Goggles/Eye Protection

Goggles or face shields, made of impact resistant materials, must be worn. Regular glasses or sunglasses are not acceptable.

B8.5.3 Shoes

Shoes or boots of durable material, free from any holes, must be worn by the driver during the competition.

ARTICLE 9: EQUIPMENT REQUIREMENTS

B9.1 Fire Extinguisher

B9.1.1 A multipurpose minimum 0.9 kg (2 pounds) ABC dry chemical fire extinguisher, rating no. 1A 10BC or equivalent must be provided.

B9.1.2 Extinguisher must be securely mounted such that the driver can direct the extinguishing agent on the fuel tank and engine area. If the driver has sufficient freedom of movement in the event of a fire to remove the extinguisher from its bracket and direct it on the above mentioned areas, the design will be allowed. If the driver does not have sufficient freedom of movement, some method must be provided to accomplish the desired result (i.e., a system of tubing, remote actuation, etc.)

B9.1.3 Remote actuation is preferred; if a tubing delivery system is used, 12.7 mm (0.5 inch) inside diameter tubing of no more than 1.2 meters (48 inches) length must be used. Tubing must direct extinguishing agent toward engine and fuel tank. Demonstration of the fire extinguisher system may be required at Technical Inspection.

B9.1.4 Alternate delivery systems will be allowed only if actual test result documentation is available through the faculty advisor. Halon fire extinguishers are not allowed.

B9.1.5 Pressure Gauge

All fire extinguishers must be equipped with a manufacturer installed pressure/charge gauge; the gauge must be readable to the technical inspectors.

B9.1.6 Fire Extinguisher Position

The fire extinguisher must be mounted such that the valve is above the bottom of the canister.

B9.2 Transponder

B9.2.1 A transponder will be attached to the front of the vehicle for lap timing purposes. The transponder will

be smaller than 13 cm x 8 cm x 4 cm (5 inches x 3 inches x 1.5 inches) and weigh less than 230 grams (0.5 pounds).

B9.2.2 The transponder must be mounted within 45 cm (18 inches) of the road surface, usually on the outside of the body.

B9.2.3 The transponder can be mounted inside the body ONLY if it is not obstructed by any conductive materials such as metal or carbon fiber. The transponder will be mounted with a piece of industrial strength, self-adhesive, hook and loop material supplied by the competition organizer at the event.

B9.3 Mirrors

B9.3.1 Vehicles must be equipped with a mirror or mirrors to ensure adequate rearward visibility. Other visibility systems are not prohibited, but the use of other visibility systems will not be permitted during Technical Inspection.

B9.3.2 The driver must be able to see a 45 cm (18 inch) square object on a vertical plane 1.52 m (5 feet) wide by 0.91 m (3 feet) high located 9.14 m (30 feet) behind and to each side of the vehicle. See illustration “Minimum Visibility Plane” in Rule B1.4 for a visual representation of this requirement.

B9.3.3 Mirrors must be securely mounted and adjustable.

B9.3.4 Mirrors may not be attached to removable panels.

B9.3.5 Mirrors must be adjustable by the driver while the driver is seated normally in the vehicle. Access doors to enable the driver to adjust the mirrors are permitted.

ARTICLE 10 - NOTICE OF POSSIBLE FUTURE RULE CHANGES

This section is intended to provide teams with advance notice of possible changes to the SAE Supermileage rules that are being considered by the Supermileage Rules Committee. Only changes that may have a significant impact on the team’s engineering design, manufacturing decisions or event preparation are listed. This section is provided only for information and is not intended to provide final text for any rules.

The following rules changes are under discussion:

- A) Driver Shielding – The driver shielding requirements may be expanded.
- B) Alternate Fuels - Use of alternative fuels for future events
- C) Engine – A different base engine may be designated due to production changes at the engine supplier. Current engines will be allowed for two successive competitions once the new engine is designated.

PART C – STATIC EVENTS

ARTICLE 1: DESIGN REPORTS

C1.1 The review of the design will require both (1) written and (2) verbal design reports.

The total design report points will be the sum of the points from the written design report and the verbal design report.

C1.2 Written Design Reports – General – 300 Points Maximum

C1.2.1 The written design report must be submitted to the Board governing the Supermileage® Competition by the date indicated on the Action Deadline in the appendix. Slight variations between the vehicle brought to the competition and the vehicle described in the design report are permitted to reflect your final design refinements. However, your team should be prepared to discuss and justify those differences with the Design Judges.

C1.2.2 The written design report serves three purposes: (1) the report is a proposal that documents the design intent and goals of the program for the purpose of securing funding, (2) the report serves as a record of the design, and (3) the report is an information document to show how the vehicle adheres to the rules.

C1.2.3 The written report must be limited to a maximum of twenty five (25) pages not including supporting data in an appendix. No specific format is specified for the written report.

C1.2.4 A maximum of three hundred (300) points will be awarded to the Written Design Report, and late reports will be assessed a penalty of twenty five (25) points per day for each business day the report is late.

C1.2.5 NOTE: A written design report must be submitted for a vehicle to compete during the dynamic portion of the competition.

C1.2.6 Feedback – Each team attending the on-site competition will receive a one (1) page sheet of comments on their written report, provided that the report has been submitted by the deadline specified in the Appendix and on the website.

C1.3 Verbal Report – 150 Points Maximum

C1.3.1 Each team will present a verbal design report to panel of judges in a question and answer format. No prepared materials, other than the vehicle itself, are allowed.

C1.3.2 Vehicle Presentation – Teams that bring their vehicle with them during the verbal report will receive a twenty five (25) point bonus.

C1.3.3 Three (3) team members must be present for the verbal design report. Teams with less than three members are required to have the entire team participate in the verbal design report.

C1.3.4 The verbal design report should demonstrate the team's understanding and application of the engineering principles that support their design.

C1.3.4 The verbal design report will only be presented on the first day of the competition as scheduled by the organizer. Teams that fail to give their report during the scheduled verbal report period will receive zero (0) points for their verbal report.

C1.3.5 Teams may schedule a time for their verbal design report after they have completed on-site registration.

C1.3.6 Verbal design reports will be scored to a maximum of one hundred fifty (150) points.

C1.4 Written Design Report Contents

C1.4.1 The written design report is intended to show the focus of the team on determining the goals for the design and the design effort to reach the established goals. The goals stated should be those of the team and hence will reflect the team members, financial resources, laboratory access, and involvement of the team.

C1.4.2 Areas of re-design must be specifically documented. The various sections of the report should indicate where design decisions are made, the basis for making the decisions, and the consequences of the decisions on the performance of the vehicle. Records of make/buy decisions are expected, as are decisions regarding performance parameters and compromises.

C1.4.3 The report should include drawings and written descriptions. Since design revision is a normal outgrowth of engineering development, changes in vehicle design between the written report submission and the competition date will be allowed. Design reports will be held in strict confidence.

C1.4.4 The following topics must be covered – and clearly labeled - in the design report:

a) **Basic Vehicle Configuration**

This topic should include general arrangement, physical dimensions, location of components, etc.

b) **Engine**

This topic must include a discussion of all modifications to the base Briggs & Stratton engine including the engineering principles that support those modifications and the team's design considerations.

The report must also include an itemized list of all engine modification. Finished, or altered, parts from some other engine, or of another manufacturers design, must be listed with the manufacturers name and part description.

c) **Powertrain Configuration**

This topic includes a discussion of the transmission of power to the wheels.

d) **Brake System**

This topic should present a design, which relates to the vehicle's top speed capability and should describe stopping distance and energy capacity of the system.

e) **Suspension and Running Gear**

This topic includes the tires, axles and other associated equipment that concerns handling and steering of the vehicle.

f) **Body/Aerodynamic Shell**

This topic includes decisions made on the basis of aerodynamic considerations as well as safety issues.

g) **Performance**

This topic should include calculations on vehicle top speed and any calculations on mileage.

h) **Cost Estimate and Manufacturing Methods**

The design report is to include a discussion of the manufacture and cost of the vehicle. Where parts, services, or materials are donated, a fair market-value of the donation must be included in the cost breakdown of the vehicle. Professional machine and fabrication services are to be included in the cost breakdown, including appropriate cost for work performed by university technicians even if the team budget is not charged directly.

Manufacturing methods and equipment used by the team should be discussed in the design report, generally as associated with the parts of the vehicle using that manufacturing method.

i) **Driver Safety Features**

The report is to include detail descriptions of all aspects of the design intended to protect the safety of the driver.

j) **General Information**

Any additional information which has not been discussed in the above items should be included here.

k) **Re-entered Vehicles**

Areas of redesign must be specifically documented (See Rule A5.3 “Re-Entered Vehicles/Engines”)

C1.5 Faculty Advisor Signature

The design report must include the signature of the team/project faculty advisor verifying that the design report has been reviewed by the advisor, and if the vehicle is being re-entered, that significant redesign has been completed.

PART D – DYNAMIC EVENT

ARTICLE 1: PERFORMANCE RUN

D1.1 The performance run will consist of each vehicle running six laps around a 2.6 km (1.6 mile) oval test track.

D1.2 Minimum Speed

The vehicle must achieve a minimum six lap average speed of 24 kph (15 mph). This means that each vehicle will be required to travel a total distance of 15.5 km (9.6 miles) in a maximum of 38.4 minutes.

D1.3 Maximum Speed

The vehicle must not exceed a single lap average speed of 40 kph (25 mph) (40.23km). This means a vehicle must take longer than 3 minutes 50 seconds to complete each lap.

D1.4 Track Grade

Vehicles must be capable of ascending a 1 percent grade and descending a 7 percent grade. Track topography can be found at <http://students.sae.org/competitions/supermileage/home.htm> .

D1.5 Slow Speed Penalty – Operating Too Slow

D1.5.1 If the minimum average speed of 24 kph (15 mph) is not maintained, a penalty will be assessed by subtracting from the km/liter (mpg) achieved.

D1.5.2 The penalty will be 4.25 km/liter (10 mpg) per second of time that the minimum average speed requirement is not met. For instance, if 39 minutes was the elapsed time for six laps, the minimum allowable time, without penalty (38 minutes 24 seconds) was exceeded by 36 seconds. The actual mileage achieved would be reduced by 153.1 km/liter (360 mpg).

D1.6 Maximum Speed Penalty – Operating Too Fast

D1.6.1 If the maximum lap average speed of 40 kph (25 mph) is exceeded, a penalty will be assessed by subtracting from the km/liter (mpg) achieved.

D1.6.2 The penalty will be 4.25 km/liter (10 mpg) per second of time that the maximum average lap speed requirement is not met. For instance, if the third lap was completed in 3 minutes 12 seconds, the minimum allowable time, without penalty (3 minutes 50 seconds) was exceeded by 38 seconds. The actual mileage achieved would be reduced by 161.5 km/liter (380 mpg).

D1.7 Start

D1.7.1 Prior to the performance run, an official fuel tank (supplied by the competition organizers) will be filled, weighed and installed on the vehicle. A member of the vehicle team will perform the installation of the fuel bottle into the vehicle.

D1.7.2 The start of the performance run will begin with the vehicle being placed on the track starting line. The vehicle engine is then started, either by the driver or his pit crew. Timing for the minimum speed requirement starts when the vehicle crosses the starting line.

D1.7.3 Vehicles cannot be push started.

D1.8 Finish

D1.8.1 Upon completion of the six lap performance run, 15.5 km (9.6 miles), the timers will record the elapsed

time. The fuel bottle will be removed by a member of the vehicle team and then weighed by the competition organizers.

- D1.8.2 The kilometer per liter (miles per gallon) calculation for the vehicle will then be computed, dividing the 15.5 km (9.6 mile) distance by the amount of fuel used.
- D1.8.3 If the maximum or minimum allowable elapsed time has been exceeded, the penalty will be computed and subtracted from the kilometer per liter (miles per gallon) calculation.

ARTICLE 2: GENERAL CONDUCT AND REGULATIONS

D2.1 Organizer Authority

The organizer(s) of the competition reserve the exclusive right to revise the schedule of the competition and/or to interpret the competition rules at any time and in any manner which is in their sole judgment, required for efficient operation or safety of the competition.

D2.2 Unsportsmanlike Conduct

In the event of unsportsmanlike conduct, the team will receive a warning from an official. A second violation will result in expulsion of the team from the competition.

D2.3 Arguments with Officials

Argument with, or disobedience to, any official may result in the team being eliminated from the competition. All members of the team may be immediately escorted from the grounds.

D2.4 Rule Violation

Violation of the rules may result in the team being eliminated from the competition. All members of the team may be immediately escorted from the grounds.

D2.5 Alcohol and Illegal Material

No alcohol, illegal drugs, weapons or other illegal material will be permitted on the event site during the competition. This rule will be in effect during the entire competition. Any violation of this rule by a team member will cause the expulsion of the entire team. This applies to both team members and faculty advisors. Any use of drugs, or the use of alcohol by an underage individual, will be reported to the local authorities for prosecution. Visitors to the competition who are affiliated with a team are considered members of the team for purposes of this rule.

D2.6 Non-Smoking Venue

The competition site is a non-smoking venue. The smoking ban applies to all areas and properties of the host corporation. Violation of this rule may lead to expulsion of the participant **and** the expulsion of the team from the competition. Visitors to the competition who are affiliated with a team are considered members of the team for purposes of this rule.

ARTICLE 3: COMPLAINTS AND PROTESTS

D3.1 Complaints

Contest officials, as designated by the local organizer, will be available to listen to any complaints about errors in the scores or any other aspect of the competition, except the rules.

D3.2 Protests

D3.2.1 Cause of Protest

If a faculty advisor or team captain feels that a complaint was not properly addressed by the competition officials, he/she may protest.

D3.2.2 Protest Format

All protests must be filed in writing to the Chief Steward by the faculty advisor or team captain only. In order to have a protest considered, a team must be willing to put up one hundred (100) points which will be forfeited if their protest is rejected.

D3.2.3 Protest Period

Protests concerning any aspect of the competition must be filed within thirty (30) minutes of the end of the round or event to which the protest pertains to.

D3.2.4 Decision

The decision of the Chief Steward is final. Any argument with the Chief Steward or with any official after a decision is rendered may result in immediate expulsion of all team members from the competition. Depending on the circumstances, individual team members or the entire team may be immediately escorted from the grounds.

APPENDIX A

2012 SAE Supermileage - Action deadlines

Eaton Corporation Proving Grounds, 19218 B Drive South, Marshall, Michigan, 49068, USA

June 7-8, 2012

All submissions must be received by the deadline. Not Postmarked

Registration

Register on-line at: www.sae.org on Tuesday, October 4, 2011 at 10:00 AM EDT.

Registration fee

Registration closes

\$600.00 USD

11:59 pm EST Monday, December 19, 2011

Engine Orders

Order engines on-line upon completion of registering

Engine order fee

\$0.00

Engine order deadline

11:59 pm EST Monday, December 19, 2011

Written Design Report

Due by March 31, 2012 – Not Postmarked

Both a hard copy and an electronic copy of the Written Design Report are required to be submitted by the Due Date. Late reports will be penalized.

One (1) hardcopy of the Written Design Report must be sent to:

Supermileage Competition
Eaton Corporation
13100 E. Michigan Ave
Galesburg, MI 49053

The electronic copy of the Written Design Report in Adobe Acrobat “PDF” file format must be sent by midnight on March 31, 2012 to: Supermileage@Eaton.com

Subject line must read: [“School Name”] Supermileage Design Report

NOTE: Supermileage Organizers reserve the right to disqualify any team from the competition if the team fails to submit both the electronic copy and the hard copy of the Written Design Report by April 1 of the competition year.

Rules Inquiries concerning SAE Supermileage

Any inquiries regarding rules or questions specific to SAE Supermileage 2012 should be sent via e-mail to Supermileage@Eaton.com

Official 2012 SAE Supermileage Website

<http://www.sae.org/students/supermw.htm>

Appendix S

SAE Technical Standards

The SAE Technical Standards Board (TSB) has made the following SAE Technical Standards available on line, **at no cost**, for use by Collegiate Design teams. Standards are important in all areas of engineering and we urge you to review these documents and to become familiar with their contents and use.

The technical documents listed below include both (1) standards that are identified in the rules and (2) standards that the TSB and the various rules committees believe are valuable references or which may be mentioned in future rule sets.

All Collegiate Design Series teams registered for competitions in North America have access to all the standards listed below - including standards not specific to your competition.

See Supermileage Rule A2.7 “Technical Standards Access” for the access procedure.

SAE Technical Standards included in the CDS Rules

Baja SAE

- J586 - Stop Lamps for Use on Motor Vehicles Less Than 2032 mm in Overall Width
- J759 - Lighting Identification Code
- J994 - Alarm - Backup – Electric Laboratory Tests
- J1741 - Discriminating Back-Up Alarm Standard

Clean Snowmobile Challenge

- J192 - Maximum Exterior Sound Level for Snowmobiles
- J1161 - Sound Measurement – Off-Road Self-Propelled Work Machines Operator-Work Cycle

Formula Hybrid

- J1318 - Gaseous Discharge Warning Lamp for Authorized Emergency, Maintenance and Service Vehicles
- J1673 - High Voltage Automotive Wiring Assembly Design

Formula SAE

- SAE 4130 steel is referenced but no specific standard is identified
- SAE Grade 5 bolts are required but no specific standard is identified

Supermileage

- J586 - Stop Lamps for Use on Motor Vehicles Less Than 2032 mm in Overall Width

SAE Technical Standards for Supplemental Use

Standards Relevant to Baja SAE

- J98 – Personal Protection for General Purpose Industrial Machines – Standard
- J183 – Engine Oil Performance and Engine Service Classification - Standard

J306 – Automotive Gear Lubricant Viscosity Classification - Standard
J429 – Mechanical and Material Requirements for Externally Threaded Fasteners – Standard
J512 – Automotive Tube Fittings - Standard
J517 – Hydraulic Hose - Standard
J1166 – Sound Measurement – Off-Road Self-Propelled Work Machines Operator-Work Cycle
J1194 – Rollover Protective Structures (ROPS) for Wheeled Agricultural Tractors
J1362 – Graphical Symbols for Operator Controls and Displays on Off-Road Self-Propelled Work Machines - Standard
J1614 – Wiring Distribution Systems for Construction, Agricultural and Off-Road Work Machines
J1703 - Motor Vehicle Brake Fluid - Standard
J2030 – Heavy Duty Electrical Connector Performance Standard
J2402 – Road Vehicles – Symbols for Controls, Indicators and Tell-Tales - Standard

Standards Relevant to Clean Snowmobile Challenge

J44 – Service Brake System Performance Requirements – Snowmobiles - Recommended Practice
J45 – Brake System Test Procedure – Snowmobiles – Recommended Practice
J68 – Tests for Snowmobile Switching Devices and Components - Recommended Practice
J89 – Dynamic Cushioning Performance Criteria for Snowmobile Seats - Recommended Practice
J92 – Snowmobile Throttle Control Systems – Recommended Practice
J192 – Maximum Exterior Sound Level for Snowmobiles - Recommended Practice
J288 – Snowmobile Fuel Tanks - Recommended Practice
J1161 – Operational Sound Level Measurement Procedure for Snowmobiles - Recommended Practice
J1222 – Speed Control Assurance for Snowmobiles - Recommended Practice
J1279 – Snowmobile Drive Mechanisms - Recommended Practice
J1282 – Snowmobile Brake Control Systems - Recommended Practice
J2567 – Measurement of Exhaust Sound Levels of Stationary Snowmobiles - Recommended Practice

Standards Relevant to Formula SAE

J183 – Engine Oil Performance and Engine Service Classification - Standard
J306 – Automotive Gear Lubricant Viscosity Classification - Standard
J429 – Mechanical and Material Requirements for Externally Threaded Fasteners – Standard
J452 - General Information – Chemical Compositions, Mechanical and Physical Properties of SAE Aluminum Casting Alloys – Information Report
J512 – Automotive Tube Fittings - Standard
J517 – Hydraulic Hose - Standard
J637 – Automotive V-Belt Drives – Recommended Practice
J829 – Fuel Tank Filler Cap and Cap Retainer
J1153 - Hydraulic Cylinders for Motor Vehicle Brakes – Test Procedure
J1154 – Hydraulic Master Cylinders for Motor Vehicle Brakes - Performance Requirements - Standard
J1703 - Motor Vehicle Brake Fluid - Standard
J2045 – Performance Requirements for Fuel System Tubing Assemblies - Standard
J2053 – Brake Master Cylinder Plastic Reservoir Assembly for Road Vehicles - Standard

Standard Relevant to Formula Hybrid

J1772 – SAE Electric Vehicle and Plug in Hybrid Conductive Charge Coupler

Standard Relevant to all CDS Competitions

J1739 – Potential Failure Mode and Effects Analysis in Design (Design FMEA) Potential Failure Mode and Effects Analysis in Manufacturing and Assembly Processes (Process FMEA) and Potential Failure Mode and Effects Analysis for Machinery (Machinery FMEA)