



Engine Components Spotlight

Ventilation system

The ProVent series for crankcase ventilation from **Mann+Hummel** includes four sizes and covers engine outputs from 20 to 1500 kW (27 to 2011 hp). The system features integrated oil separation and prevents the formation of deposits in the intake system



while reducing diesel engine oil consumption and emissions. Designed for latest-generation turbocharged engines, the ProVent series uses a coalescence separator integrated into the system with a pressure controller to filter blow-by gases and reduce the residual oil content to a minimum. The compact unit features a robust design and is suited for industrial applications with flow rates of 20 to 1000 L/min (5 to 264 gal/min).

Aluminum pistons

A cooled aluminum ring carrier piston from **Mahle** is recommended for medium heavy-duty commercial vehicle diesel engines with high loads and peak cylinder pressures of more than 220 bar (3190 psi). Constructed from high-temperature-resistant aluminum alloy, the pistons' cooled ring carrier enables a reduction in bowl edge temperature by as much as 30°C (54°F) and extends service life. Other benefits include improved oil consumption and blow-by as well as combustion optimization while maintaining production-level dimensions.

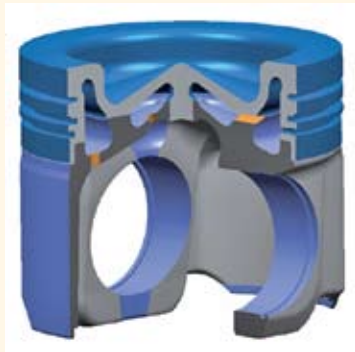

Rotating torque sensors

PCB Piezotronics' series 4100 and 4200 rotating torque transducers use non-contact, rotary transformers for sending excitation voltage to, and receiving measurement signals from, the rotating strain gage sensor. The maintenance-free, rotary transformer design eliminates the need for replacing worn brushes. The units are suitable



for use in engine and chassis dynamometers, fuel pumps, hydraulic pumps, driveshafts, transmissions, fans, and electric motors. The series 4100 and 4200 rotating torque sensors offer capacities from 0.35 to 11,300 N·m (0.26 to 8334 lb-ft) full scale and maximum speeds to 15,000 rpm. In addition to the torque output signal, an optional pickup provides an output proportional to speed.

Engine air pre-cleaners

Parker Hannifin/Racor Division's AFAP Engine Air Pre-Cleaners are designed to be mounted outside the hood and to be connect-



ed to the air filter intake of a gasoline or diesel engine air cleaner. Applications include all slow-moving and industrial equipment such as agricultural machinery; earth-moving, construction, and mining equipment; pumping plants; generator sets; material-handling equipment; snow-removal equipment; and street sweepers. Benefits include easy installation, longer life of engine air cleaners, and durable design.

Engine interface

As a response to the prevalence of electronically controlled engines in the off-highway industry, **Siemens**



VDO has developed a series of accelerator pedals that transmit pedal position electronically instead of mechanically. Consisting of a base module, operating lever, pedal plate, and return springs, the suspended pedal is designed to be a complete, compact unit. A noncontact Hall sensor, which is integrated into the unit, processes the electronically generated signals that are triggered by pedal movement. Due to its flexibility, the pedal can be adapted to different engine management interfaces if necessary. Analog and digital are available for use with various engine interfaces.

tools of the trade



Power pack

Atlas Copco Construction Tools offers the diesel-powered LP 13-20 DEL hydraulic power pack, which features reduced engine load in demanding applications such as heavy handheld hydraulic beakers. With a rugged design and reinforced chassis to withstand vibrations during operation, the 256-lb (116-kg) LP 13-20 DEL is powered by an air-cooled 10-hp (7-kW) engine with recoil and electric start. Other features include a hydraulic oil flow of 5.3 gal/min (20 L/min), a maximum pressure of 2175 psi (150 bar), and an oil capacity of 1.3 gal (5 L). A thermostatically controlled air

blast oil cooler on the power pack warms up the engine while protecting the oil from overheating. The power pack is suitable for tunneling and other poorly ventilated diesel work areas in the construction industry.



Hydrostatic transmission

Poclair Hydraulics has partnered with a high-pressure hydraulic pump specialist to offer high-performance hydrostatic transmissions for mobile machinery—at the heart of that is a robust variable displacement pump. The variable displacement control is designed by the firm and the transmission is managed by SmartDrive, a range of electronic computers. This mechatronic unit (pump, control, and computer) features a feedback function that uses a recopy potentiometer that measures the position of the

pump's swash plate. The ease of implementing the components enables the constructor to develop a machine prototype quickly. The machine's configuration is directly reproducible, enabling the mass production of identically functioning machines.



Tubeless sealing ring

The **Continental** tubeless sealing ring (TSR) allows tubeless industrial tires to be fitted to standard industrial tire rims that, because of their design, would normally require an inner tube and bead flap. The TSR consists of a rubber ring with an integrated tire valve. This rubber ring fits on the cylindrical part of the rim between the two tire beads and provides an airtight seal for the air chamber without the need for an inner tube and bead flap. According to the company, the TSR is less susceptible to damage than an inner tube, which makes fitting easier. If the tire were to be penetrated by a foreign body, it would not normally affect the vehicle's driving stability.

pins will ratchet down body rails until the slide box impacts with the stop bar. PinLoc is suitable for use on dry and refrigerated van trailers in capacities of 38,000 and 40,000 lb (17,000 and 18,000 kg). PinLoc is currently in production.



Tire pressure monitoring

SmartTire's SmartWave tire-pressure monitoring system (TPMS) is a real-time electronic system designed to actively and accurately measure the air pressure and temperature for each tire on a vehicle. The system transmits data via wireless to a receiver mounted on the vehicle and displays the information in the cab. According to the company, SmartWave TPMS simplifies the tire maintenance process resulting in an overall reduction of fleet operating costs. Benefits include alerting the driver to a specific under-inflated tire or providing fleet maintenance staff with the capability to quickly measure tire pressure. Suitable for all wheel and tire types, the system can be installed at any point in the vehicle's life.

Increase Hydraulic Motor life

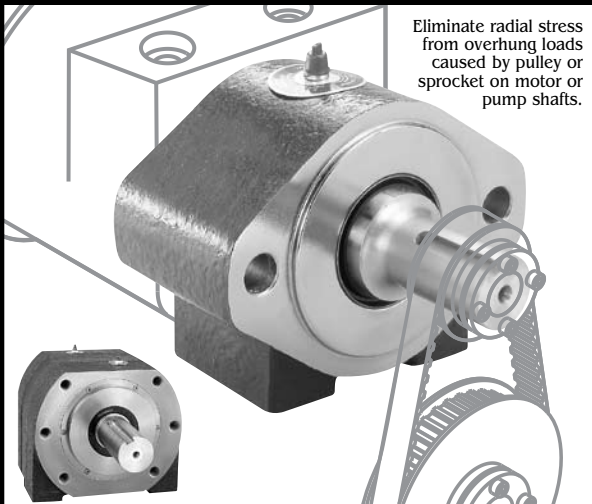

Eliminate radial stress from overhung loads caused by pulley or sprocket on motor or pump shafts.

- OHLA's mate directly to motor shaft and absorb stress with heavy-duty, built-in bearings.

- OHLA's seal out abrasive particles, cut servicing costs and save money.

- SAE A, B, C, C-C, D, E & F mount. 15 models plus specials to fit all standard SAE motors.

FREE Sizing Software, 3D CAD Drawings & Catalog On Disk

ZERO-MAX®

800-533-1731 Fax 763-546-8260 www.zero-max.com



Slider locking mechanism

The RideSentry trailer suspension from **ArvinMeritor** features a PinLoc slider locking mechanism. The PinLoc mechanism reduces the potential for incidents by using an angled pin design and an air assist with a parking brake interlock to securely engage the slider pins before the trailer is put in transit. These features combine to compensate for operator error and ensure pins engage in body rails. If the trailer is operated without pins engaged and trailer brakes are applied, conventional



Next-gen fitting

The BPO3N ferrule from **Olmark** is suitable with both spiraled and braided hose, without jeopardizing its pressure resistance performances. The ferrules have been tested with 1 million cycles of pulsating pressure, against the standard 400,000 required by **SAE J517** specifications, at a rate 33% higher than the maximum working pressure. The device is a no-skive component and can be assembled to the hose directly from the box.



Two-zone oven

No. 803 from **Grieve** is an electrically heated, two-zone walk-in oven, currently used in tandem with a customer's conveyor system for heating 27-ft (8.2-m) long pallets of vacuum laminations. Maximum operating temperature is 650°F (343°C) and workspace dimensions are 6 x 28 ft (1.8 x 8.5 m), in two 14-ft (4.3-m) zones, x 5 ft (1.5 m). A 100 kW heat input is installed in each zone in Incoloy sheathed tubular heating elements, while a 12,500 ft³/min (354 m³/min), 10 hp (7.5 kW) recirculating blower provides horizontal airflow to the workload in each zone. A top-mounted chamber is located above each heating zone, as well, on the oven.



High-pressure hoses

DN51 (size -32) high-pressure hoses from **Eaton** have been expanded to the six-spiral segment. The hose is designed for extreme demands under operating pressures of up to 420 bar (6092 psi). The Aeroquip GH466-32 meets high-pressure and long-life requirements. It is DIN EN 856 and **SAE** 100/R15 certified as well as ISO6803 tested for pressure impulse. The hose even passes 1 million pressure impulse cycles at 504 bar (7310 psi) with leakage "Class 0" (well above the industry-standard 500,000 cycles). It also withstands over 1750 bar (25,400 psi) before bursting—in excess of the industry-standard 1680 bar (24,400 psi). This high durability maximizes equipment uptime.

Electronic tire monitoring

Developed for surface mining vehicles, the **Michelin** earthmover management system (MEMS) measures tire temperature and pressure in real time. The system is comprised of sensors located in the tires and a receiver in the cab that is connected directly to the mine operations control center. The sensors emit a signal in real time whenever preconfigured temperature and pressure levels are reached. MEMS warns the user of any loss of pressure or tire overheating. The system allows users to take preventative measures by warning of the damage that could occur to the tire if pressure goes low or temperature gets too high before it actually occurs, thereby offering savings and improving productivity. MEMS will be sold and installed individually on 49-in and larger replacement tires.



Linear actuators

The ElecTrak Pro series of electric linear actuators from **Thomson** is a zero-maintenance electromechanical solution that offers standard features that provide machine builder and user benefits, according to the company. Featuring quick and easy installation, accuracy, repeatability, and reliability as well as advanced control over critical machine operations, the actuators cost-effectively provide maximized machine uptime. They feature a compact design and short retracted length coupled with a lightweight and high strength IP66 housing, with IP67 protection as an option. As a result, the actuators are suitable for use in tough, space-restricted mobile off-highway vehicle applications such as utility and construction vehicles and lawn and turf care.



Vibration monitor

Grammer's vibration dosimeter continuously records all vibrations that occur during the course of a machine operator's eight-hour shift, calculates the exposure values, and alerts the operator if the maximum permissible levels as defined by the European Union directive are reached or exceeded. The employer can then take appropriate action to prevent this from recurring. The device, which attaches to a vehicle's seat, runs on a rechargeable battery and can be quickly installed in different vehicles. The captured data can also be easily transferred to a PC for documentation purposes. Pressing a reset button deletes all data and readies the

instrument to begin a fresh series of measurements.



Mobile hydraulic sensor

Building on its mobile hydraulic sensor technology, **MTS Systems** has developed a new MH sensor with a CAN bus interface. The compact sensor features Temposonics technology and is intended for use in welded and tie-rod cylinders, or any space-limited cylinder applications. The sensor works with CAN J1939 and CANopen, measuring displacement and speed variables. A mechanical housing provides a robust wire/cable exit that improves the level of strain relief and sealing, according to the company. Designed for rugged environments, the sensor is suited for use in construction, agriculture, and off-highway equipment.



HEX-FLX
Economical Plastic
Flywheel Coupling



L-Series &
Pump Motor Mounts



Engine Housing
Kits Standard
or HEX-FLX



Flexible Couplings

POWER TRANSMISSION PRODUCTS

HAYES®

www.hayescouplings.com



Hayes "Original"
Flywheel Coupling &
Pump Mount Plate



Straight Sided Splines
For Marine Applications



Bearing Supported
Stub-Shafts

Phone 231-879-3372 Fax 231-879-4330
Catalog Request info@hayescouplings.com



**On-Road.
Off-Road.
ALL Roads lead to the**

SAE 2007 Commercial Vehicle Engineering Congress and Exhibition

**October 30 – November 1, 2007
Donald E. Stephens Convention Center
Rosemont, Illinois USA**

Executive Council Leadership Provided by:



This year's event is being held in conjunction with the
2007 Powertrain & Fluid Systems Conference and Exhibition.

SAE Members attend FREE!*
****Requires event pre-registration***

SAE J1939

Standards Collection on the Web

The Real-Time Controller Area Network (CAN)
Solution for Heavy Duty Applications
store.sae.org/j1939

For more information, contact:

SAE Customer Service

1-724-776-4970

Fax: 1-724-776-0790

E-mail: CustomerService@sae.org

For the latest event information, visit

www.sae.org/comvec



SAE International™